



ESAB Cutmaster® 120 PLASMA CUTTING SYSTEM SL100 1Torch™

Operating
Manual



Art # A-12776_AB

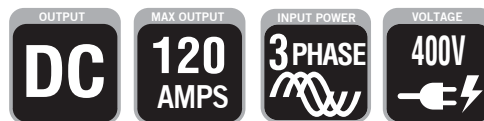

Revision: AC

Issue Date: August 14, 2015

Manual No.: 0-5398

esab.eu



WE APPRECIATE YOUR BUSINESS!

Congratulations on your new ESAB product. We are proud to have you as our customer and will strive to provide you with the best service and reliability in the industry. This product is backed by our extensive warranty and world-wide service network. To locate your nearest distributor or service agency, visit us on the web at www.esab.eu.

This Operating Manual has been designed to instruct you on the correct use and operation of your ESAB product. Your satisfaction with this product and its safe operation is our ultimate concern. Therefore please take the time to read the entire manual, especially the Safety Precautions. They will help you to avoid potential hazards that may exist when working with this product.

YOU ARE IN GOOD COMPANY!

The Brand of Choice for Contractors and Fabricators Worldwide.

ESAB is a Global Brand of manual and automation Plasma Cutting Products.

We distinguish ourselves from our competition through market-leading, dependable products that have stood the test of time. We pride ourselves on technical innovation, competitive prices, excellent delivery, superior customer service and technical support, together with excellence in sales and marketing expertise.

Above all, we are committed to developing technologically advanced products to achieve a safer working environment within the welding industry.



WARNING

Read and understand this entire Manual and your employer's safety practices before installing, operating, or servicing the equipment. While the information contained in this Manual represents the Manufacturer's best judgement, the Manufacturer assumes no liability for its use.

Plasma Cutting Power Supply
ESAB Cutmaster® 120
SL100 1Torch™
Operating Manual Number 0-5398

Published by:
ESAB Group Inc.
2800 Airport Rd.
Denton, TX 76208
(940) 566-2000

www.esab.eu

Copyright 2015 by ESAB

All rights reserved.

Reproduction of this work, in whole or in part, without written permission of the publisher is prohibited.

The publisher does not assume and hereby disclaims any liability to any party for any loss or damage caused by any error or omission in this Manual, whether such error results from negligence, accident, or any other cause.

Original Publication Date: January 15, 2015
Revision Date: August 14, 2015

Record the following information for Warranty purposes:

Where Purchased: _____

Purchase Date: _____

Power Supply Serial #: _____

Torch Serial #: _____

**Be sure this information reaches the operator.
You can get extra copies through your supplier.**

CAUTION

These INSTRUCTIONS are for experienced operators. If you are not fully familiar with the principles of operation and safe practices for arc welding and cutting equipment, we urge you to read our booklet, "Precautions and Safe Practices for Arc Welding, Cutting, and Gouging," Form 52-529. Do NOT permit untrained persons to install, operate, or maintain this equipment. Do NOT attempt to install or operate this equipment until you have read and fully understand these instructions. If you do not fully understand these instructions, contact your supplier for further information. Be sure to read the Safety Precautions before installing or operating this equipment.

USER RESPONSIBILITY

This equipment will perform in conformity with the description thereof contained in this manual and accompanying labels and/or inserts when installed, operated, maintained and repaired in accordance with the instructions provided. This equipment must be checked periodically. Malfunctioning or poorly maintained equipment should not be used. Parts that are broken, missing, worn, distorted or contaminated should be replaced immediately. Should such repair or replacement become necessary, the manufacturer recommends that a telephone or written request for service advice be made to the Authorized Distributor from whom it was purchased.

This equipment or any of its parts should not be altered without the prior written approval of the manufacturer. The user of this equipment shall have the sole responsibility for any malfunction which results from improper use, faulty maintenance, damage, improper repair or alteration by anyone other than the manufacturer or a service facility designated by the manufacturer.

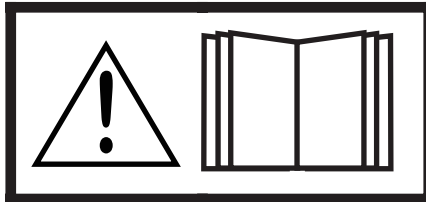

**READ AND UNDERSTAND THE INSTRUCTION MANUAL BEFORE INSTALLING OR
OPERATING.
PROTECT YOURSELF AND OTHERS!**

Declaration of Conformity



We **ESAB Group Inc.**
of **2800 Airport Road**
Denton, TX 76207 U.S.A.

in accordance with the following Directive(s):

- **2006/95/EC The Low Voltage Directive, entering into force 16 January 2007**
- **2004/108/EC The Electromagnetic Compatibility (EMC) Directive, entering into force 20 July 2007**
- **RoHS Directive 2001/EC, entering into force 2 January 2013**

hereby declare that:

Equipment: PLASMA CUTTING SYSTEM

Model Name/Number: ESAB Cutmaster® 120

Market Release Date: May 30, 2015

is in conformity with the applicable requirements of the following harmonized standards:

- **EN 60974-1:2012 Arc Welding Equipment - Part 1: Welding power sources.**
- **EN 60974-10:2007 Arc Welding Equipment - Part 10: Electromagnetic compatibility (EMC) requirements**

*Classification: The equipment described in this document is **Class A** and intended for industrial use.*

Manufacturer's Authorized Representative
Steve Ward V.P. Europe and General Manager

Address: ESAB
Europa Building
Chorley N Industrial Park
Chorley, Lancashire,
England PR6 7BX

Date: May 30, 2015

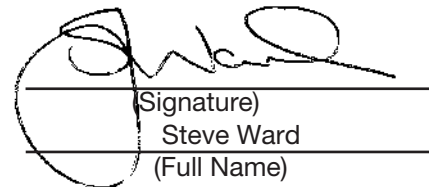

(Signature)
Steve Ward

(Full Name)

V.P. Europe and General Manager
(Position)



WARNING

This Class A equipment is not intended for use in residential locations where the electrical power is provided by the public low-voltage supply system. There may be potential difficulties in ensuring electromagnetic compatibility in those locations, due to conducted as well as radiated disturbances.

TABLE OF CONTENTS

SECTION 1: SAFETY	1-1
1.0 Safety Precautions.....	1-1
РАЗДЕЛ 1: БЕЗОПАСНОСТ	1-1
ČÁST 1: Bezpečnostní	1-1
SEKTION 1: SIKKERHEDSFORANSTALTNINGER	1-1
KAPITEL 1: SICHERHEIT	1-1
SECCIÓN 1: SEGURIDAD	1-1
PEAÜKK 1: Ohutus	1-1
KAPPALE 1: Turvallisuus	1-1
CHAPITRE 1 : SÉCURITÉ	1-1
SECTION 1: Važne sigurnosne	1-1
1. FEJEZET: Biztonsági	1-1
SEZIONE 1: SICUREZZA	1-1
1 SKYRIUS. Saugos	1-1
1 NODAĻA : Drošības	1-1
HOOFDSTUK 1: VEILIGHEID	1-1
AVSNITT 1: Sikkerhet	1-1
ROZDZIAŁ 1: BEZPIECZEŃSTWO	1-1
SECÇÃO 1: Segurança	1-1
SECȚIUNEA 1: Securitate	1-1
РАЗДЕЛ 1, Правила техники	1-1
ČASŤ 1: Bezpečnostné pokyny	1-1
RAZDELEK 1 - VARNOST	1-1

TABLE OF CONTENTS

AVSNITT 1: SÄKERHET	1-1
1.0 Säkerhetsåtgärder.....	1-1
SECTION 2 SYSTEM: INTRODUCTION	2-1
2.01 How To Use This Manual	2-1
2.02 Equipment Identification	2-1
2.03 Receipt Of Equipment.....	2-1
2.04 Power Supply Specifications	2-2
2.05 Input Wiring Specifications	2-3
2.06 Power Supply Features	2-4
SECTION 2 TORCH: INTRODUCTION	2T-1
2T.01 Scope of Manual	2T-1
2T.02 General Description	2T-1
2T.03 Specifications	2T-1
2T.04 Options And Accessories	2T-2
2T.05 Introduction to Plasma	2T-2
SECTION 3 SYSTEM: INSTALLATION	3-1
3.01 Unpacking	3-1
3.02 Lifting Options.....	3-1
3.03 Primary Input Power Connections	3-1
3.04 Gas Connections	3-2
SECTION 3 TORCH: INSTALLATION.....	3T-1
3T.01 Torch Connections	3T-1
3T.02 Setting Up Mechanical Torch	3T-1
SECTION 4 SYSTEM: OPERATION	4-1
4.01 Front Panel Controls / Features.....	4-1
4.02 Preparations for Operation	4-2
SECTION 4 TORCH: OPERATION	4T-1
4T.01 Torch Parts Selection.....	4T-1
4T.02 Cut Quality	4T-1
4T.03 General Cutting Information.....	4T-2
4T.04 Hand Torch Operation.....	4T-3
4T.05 Gouging	4T-6
4T.06 Mechanized Torch Operation.....	4T-7
4T.07 Parts Selection for SL100 Torch Cutting.....	4T-8
4T.08 Recommended Cutting Speeds for SL100 Torch With Exposed Tip	4T-9
4T.09 Recommended Cutting Speeds for SL100 Torch With Shielded Tip	4T-14
PATENT INFORMATION.....	4T-20

TABLE OF CONTENTS

SECTION 5 SYSTEM: SERVICE	5-1
5.01 General Maintenance	5-1
5.02 Maintenance Schedule	5-2
5.03 Common Faults	5-2
5.04 Fault Indicator	5-3
5.05 Basic Troubleshooting Guide.....	5-4
5.06 Power Supply Basic Parts Replacement	5-6
SECTION 5 TORCH: SERVICE	5T-1
5T.01 General Maintenance	5T-1
5T.02 Inspection and Replacement of Consumable Torch Parts.....	5T-2
SECTION 6: PARTS LISTS	6-1
6.01 Introduction	6-1
6.02 Ordering Information.....	6-1
6.03 Power Supply Replacement	6-1
6.04 Replacement Power Supply Parts	6-1
6.05 Options and Accessories	6-2
6.06 Replacement Parts for Hand Torch	6-3
6.07 Replacement Parts - for Machine Torches with Unshielded Leads	6-4
6.08 Torch Consumable Parts (SL100).....	6-6
APPENDIX 1: SEQUENCE OF OPERATION (BLOCK DIAGRAM)	A-1
APPENDIX 2: DATA TAG INFORMATION	A-2
APPENDIX 3: TORCH PIN - OUT DIAGRAMS	A-3
APPENDIX 4: TORCH CONNECTION DIAGRAMS	A-4
APPENDIX 5: SYSTEM SCHEMATIC, 400V UNITS	A-6
Revision History	A-8

This Page Intentionally Blank

SECTION 1: SAFETY

1.0 Safety Precautions

Users of ESAB welding and plasma cutting equipment have the ultimate responsibility for ensuring that anyone who works on or near the equipment observes all the relevant safety precautions. Safety precautions must meet the requirements that apply to this type of welding or plasma cutting equipment. The following recommendations should be observed in addition to the standard regulations that apply to the workplace.

All work must be carried out by trained personnel well acquainted with the operation of the welding or plasma cutting equipment. Incorrect operation of the equipment may lead to hazardous situations which can result in injury to the operator and damage to the equipment.

1. Anyone who uses welding or plasma cutting equipment must be familiar with:
 - its operation
 - location of emergency stops
 - its function
 - relevant safety precautions
 - welding and / or plasma cutting
2. The operator must ensure that:
 - no unauthorized person stationed within the working area of the equipment when it is started up.
 - no one is unprotected when the arc is struck.
3. The workplace must:
 - be suitable for the purpose
 - be free from drafts
4. Personal safety equipment:
 - Always wear recommended personal safety equipment, such as safety glasses, flame proof clothing, safety gloves.
 - Do not wear loose fitting items, such as scarves, bracelets, rings, etc., which could become trapped or cause burns.
5. General precautions:
 - Make sure the return cable is connected securely.
 - Work on high voltage equipment may only be carried out by a qualified electrician.
 - Appropriate fire extinguishing equipment must be clearly marked and close at hand.
 - Lubrication and maintenance must not be carried out on the equipment during operation.



Dispose of electronic equipment at the recycling facility!

In observance of European Directive 2002/96/EC on Waste Electrical and Electronic Equipment and its implementation in accordance with national law, electrical and/or electronic equipment that has reached the end of its life must be disposed of at a recycling facility.

As the person responsible for the equipment, it is your responsibility to obtain information on approved collection stations.

For further information contact the nearest ESAB dealer.

ESAB can provide you with all necessary cutting protection and accessories.

ESAB CUTMASTER 120

WARNING	Arc welding and cutting can be injurious to yourself and others. Take precautions when welding and cutting. Ask for your employer's safety practices which should be based on manufacturers' hazard data.
----------------	---

ELECTRIC SHOCK - Can kill.

- Install and earth (ground) the welding or plasma cutting unit in accordance with applicable standards.
- Do not touch live electrical parts or electrodes with bare skin, wet gloves or wet clothing.
- Insulate yourself from earth and the workpiece.
- Ensure your working stance is safe.

FUMES AND GASES - Can be dangerous to health.

- Keep your head out of the fumes.
- Use ventilation, extraction at the arc, or both, to take fumes and gases away from your breathing zone and the general area.

ARC RAYS - Can injure eyes and burn skin.

- Protect your eyes and body. Use the correct welding / plasma cutting screen and filter lens and wear protective clothing.
- Protect bystanders with suitable screens or curtains.

FIRE HAZARD

- Sparks (spatter) can cause fire. Make sure therefore that there are no inflammable materials nearby.

NOISE - Excessive noise can damage hearing.

- Protect your ears. Use earmuffs or other hearing protection.
- Warn bystanders of the risk.

MALFUNCTION - Call for expert assistance in the event of malfunction.

READ AND UNDERSTAND THE INSTRUCTION MANUAL BEFORE INSTALLING OR OPERATING.
PROTECT YOURSELF AND OTHERS!

WARNING	Do not use the power source for thawing frozen pipes.
----------------	---

CAUTION	Class A equipment is not intended for use in residential locations where the electrical power is provided by the public low-voltage supply system. There may be potential difficulties in ensuring electromagnetic compatibility of class A equipment in those locations, due to conducted as well as radiated disturbances.	
----------------	--	---

CAUTION	This product is solely intended for metal removal. Any other use may result in personal injury and / or equipment damage.
----------------	---

CAUTION	Read and understand the instruction manual before installing or operating.	
----------------	--	---

РАЗДЕЛ 1: БЕЗОПАСНОСТ

1.0 Безопасност Предпазни мерки

Потребителите на оборудване ESAB носят пълната отговорност за осигуряване спазването на всички приложими мерки за безопасност на всеки работещ с оборудването или в близост до него. Мерките за безопасност трябва да отговарят на всички изисквания, приложими за типа оборудване. В допълнение към стандартните наредби, приложими за работното място, е необходимо да се спазват следните препоръки:

Всички дейности трябва да се извършват от обучен персонал, добре запознат с работата със оборудването. Неправилната работа с оборудването може да доведе до опасни ситуации, които да предизвикат нараняване на оператора или повреда на оборудването.

1. Всеки, който работи със заваръчното оборудване, трябва да е запознат с:
 - неговата работа
 - разположението на аварийните стопове
 - неговото функциониране
 - съответните мерки за безопасност
 - начините за заваряване и рязане
2. Операторът трябва да гарантира, че:
 - при стартиране на оборудването в работния участък не присъстват неупълномощени лица
 - при запалване на дъгата няма незащитени лица
3. Работното място трябва:
 - да бъде подходящо за целта
 - да няма течение
4. Лично защитно оборудване
 - Винаги носете препоръчано защитно оборудване като предпазни очила, огнезащитно облекло и защитни ръкавици.
 - Не носете недобре закрепени предмети като шалове, гривни, пръстени и пр., които могат да бъдат захванати и да предизвикат изгаряния.
5. Общи мерки за безопасност
 - Уверете се, че възвратният кабел е здраво закрепен.
 - Работи с оборудване под високо напрежение могат да се извършват само от квалифициран електротехник.
 - Съответното пожарогасително оборудване трябва да е ясно обозначено и удобно разположено.
 - Смазването и поддръжката не трябва да се извършват по време на работа с оборудването.



Унищожавайте електронното оборудване чрез предаване в пункт за рециклиране!

В съответствие с европейската Директива 2002/96/ЕО относно отпадъци от електрическо и електронно оборудване и нейното прилагане съгласно националното законодателство, електрическото и/или електронното оборудване, което е достигнало до края на цикъла си на експлоатация, трябва да бъде унищожено чрез предаване в пункт за рециклиране.

Тъй като Вие сте лицето, което отговаря за оборудването, Вие трябва да потърсите информация за одобрените пунктове за събиране на подобно оборудване.

За допълнителна информация свържете се с най-близкия дилър на ESAB .

ESAB е в състояние да предостави всички необходими средства за защита при рязане и принадлежности.

ESAB CUTMASTER 120

ПРЕДУПРЕЖДЕНИЕ	Електродъговото заваряване и рязане може да доведе до нараняване на вас и други лица. При заваряване и рязане предприемете необходимите предпазни мерки. Потърсете информация за практиките за безопасност на вашия работодател, които трябва се основават на данните за опасност, предоставени от производителя.
-----------------------	---

ЕЛЕКТРИЧЕСКИЯТ УДАР - може да е смъртоносен.

- Монтирайте и заземете оборудването в съответствие с приложимите стандарти.
- Не докосвайте с голи ръце, мокри ръкавици или облекло електрически части и електроди, намиращи се под напрежение.
- Изолирайте от земята себе си и работния детайл.
- Заемете безопасна работна стойка.

ГАЗОВЕ И ДИМ - Могат да представляват опасност за здравето

- Дръжте главата си далеч от димните газове.
- Използвайте нагнетателна вентилация, смукателна в участъка на дъгата или и двете за отвеждане на дим и газове от зоната на дишане и работното пространство.

ЕЛЕКТРОДЪГОВО ИЗЛЪЧВАНЕ - Може да нарани очите и да предизвика изгаряния върху кожата.

- Защитете очите и тялото си. Използвайте правилния модел заваръчна маска и филтър и носете защитно облекло.
- Защитете стоящите в близост лица с подходящи екрани или завеси.

ОПАСНОСТ ОТ ПОЖАР

- Искрите (разтопени пръски) могат да предизвикат пожар. Уверете се, че в близост няма запалителни материали.

ШУМ - Прекомерният шум може да увреди слуха

- Защитете ушите си. Използвайте слушалки или други средства за защита на слуха.
- Предупредете стоящите наблизо лица за съществуващата опасност.

НЕИЗПРАВНОСТ - В случай на неизправност потърсете експертна помощ.

Преди монтиране или работа прочетете и разберете ръководството за експлоатация.

ЗАЩИТЕТЕ СЕБЕ СИ И ДРУГИТЕ!

ПРЕДУПРЕЖДЕНИЕ	Не използвайте захранващия източник за размразяване на замръзнали части.
-----------------------	--

ВНИМАНИЕ	Оборудването от клас А не е предназначено за употреба в жилищни помещения, в които електрозахранването се осъществява от обществената мрежа под ниско напрежение. В такива помещения е възможно възникване на потенциални затруднения, свързани с електромагнитната съвместимост на оборудване от клас А, вследствие на проводими или излъчващи повърхности.	
-----------------	--	---

ВНИМАНИЕ	Настоящият продукт е изцяло предназначен за метален отстраняване. Друга употреба може да доведе до нараняване и / или повреда на оборудването.
-----------------	--

ВНИМАНИЕ	Преди монтиране или работа прочетете и разберете ръководството за експлоатация.	
-----------------	---	---

ODDÍL 1: BEZPEČNOSTNÍ OPATŘENÍ

1.0 Bezpečnostní opatření

Uživatel svařovacího a plazmového řezacího zařízení ESAB nese plnou zodpovědnost za zajištění toho, aby každý, kdo pracuje se zařízením nebo v jeho blízkosti, dodržoval všechna příslušná bezpečnostní opatření. Bezpečnostní opatření musí vyhovovat požadavkům, které se týkají tohoto druhu svařovacího nebo plazmového řezacího zařízení. Následující doporučení by měla být dodržována jako doplněk ke standardním předpisům, které se týkají pracoviště.

Veškeré práce musí provádět kvalifikovaní pracovníci dobře obeznámení s obsluhou svařovacího nebo plazmového řezacího zařízení. Nesprávná obsluha zařízení může vést k nebezpečným situacím, které mohou mít za následek poranění obsluhy nebo poškození zařízení.

1. Každý, kdo používá svařovací nebo plazmové řezací zařízení, musí být plně seznámen s:
 - jeho obsluhou
 - umístěním nouzových vypínačů
 - jeho funkcí
 - příslušnými bezpečnostními opatřeními
 - svařováním, plazmovým řezáním nebo s obojím
2. Obsluha musí zajistit, aby:
 - se nikdo neoprávněný nenacházel při spuštění zařízení v jeho pracovním prostoru.
 - nikdo nebyl během hoření oblouku bez náležité ochrany.
3. Pracoviště musí:
 - být vhodné pro daný účel
 - být chráněno před průvanem
4. Pomůcky osobní ochrany:
 - Vždy noste doporučené ochranné pomůcky, jako jsou ochranné brýle, nehořlavý oděv a ochranné rukavice.
 - Nenoste volné doplňky, jako jsou šály, náramky, prsteny atd., kterými byste mohli zachytit nebo si způsobit popáleniny.
5. Obecná opatření:
 - Ujistěte se, že je zemnicí kabel bezpečně připojen.
 - Pracovat na vysokonapěťovém zařízení **smí pouze kvalifikovaný elektrotechnik**.
 - Patřičné hasicí zařízení musí být jasně označeno a po ruce.
 - Mazání a údržba zařízení **se nesmí** provádět za provozu.



Elektronická zařízení likvidujte v recyklačním zařízení!

V souladu s evropskou směrnicí 2002/96/ES o likvidaci elektrických a elektronických zařízení a její implementací podle státních zákonů se musí elektrické zařízení, které dosáhlo konce životnosti, zlikvidovat v recyklačním zařízení.

Jako osoba zodpovědná za zařízení máte povinnost informovat se o schválených sběrných místech.

Chcete-li další informace, obraťte se na nejbližšího prodejce společnosti ESAB.

Společnost ESAB vám může poskytnout všechny potřebné ochranné prostředky a příslušenství pro řezání.

ESAB CUTMASTER 120

VAROVÁNÍ

SVAROVÁNÍ A PLAZMOVÉ ŘEZÁNÍ MŮŽE ZPŮSOBIT ZRANĚNÍ VÁM I OSTATNÍM. PŘI SVAROVÁNÍ NEBO ŘEZÁNÍ DODRŽUJTE BEZPEČNOSTNÍ OPATŘENÍ. VYŽÁDEJTE SI BEZPEČNOSTNÍ PŘEDPISY SVÉHO ZAMĚSTNAVATELE, KTERÉ BY MĚLY VYCHÁZET Z MOŽNÝCH RIZIK UVÁDĚNÝCH VÝROBCEM.

ÚRAZ ELEKTRICKÝM PROUDEM - Může být smrtelný.

- Nainstalujte a uzemněte svařovací nebo plazmovou řezací jednotku v souladu s příslušnými předpisy.
- Nedotýkejte se živých elektrických součástí ani elektrod holou kůží, vlhkými rukavicemi nebo vlhkým oděvem.
- Izolujte se od uzemnění a od svařovaného předmětu.
- Ujistěte se, že je Váš pracovní postoj bezpečný.

KOUŘ A PLYNY - Mohou být zdraví nebezpečné.

- Držte hlavu stranou od plyných zplodin.
- Používejte ventilaci, odsávání u oblouku nebo obojí, aby se plynné zplodiny nedostaly do oblasti dýchacích cest a okolního prostoru.

ZÁŘENÍ OBLOUKU - Může způsobit poranění očí a popálení pokožky.

- Chraňte svůj zrak a tělo. Používejte správné svářečské štíty a ochranné brýle a noste ochranný oděv.
- Chraňte osoby v okolí vhodnými štíty nebo clonami.

NEBEZPEČÍ POŽÁRU

- Jiskry (odstříkující žhavý kov) mohou způsobit požár. Zajistěte, aby se v blízkosti nenacházely žádné hořlavé materiály.

HLUK - Nadměrný hluk může poškodit sluch.

- Chraňte svoje uši. Používejte protihluková sluchátka nebo jinou ochranu sluchu.
- Varujte osoby v okolí před tímto nebezpečím.

PORUCHA - V případě poruchy přivolejte odbornou pomoc.

PŘED INSTALACÍ A POUŽÍVÁNÍM ZAŘÍZENÍ SI PROSTUDUJTE UŽIVATELSKOU PŘÍRUČKU TAK, ABYSTE JÍ ROZUMĚLI. CHRAŇTE SEBE I OSTATNÍ!

VAROVÁNÍ

Nepoužívejte tento napájecí zdroj pro rozmrazování potrubí.

UPOZORNĚNÍ

Zařízení "class A" není určeno k používání v obytných oblastech, v nichž je elektrické napájení zajišťováno veřejnou, nízkonapětovou rozvodnou sítí. Kvůli rušení šířenému vedením a vyzařováním se mohou v takových oblastech objevit případné obtíže se zaručením elektromagnetické kompatibility u zařízení "class A".

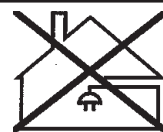

UPOZORNĚNÍ

Tento výrobek je určen výlučně pro plazmové řezání. Jakékoliv jiné použití může přivodit zranění nebo škodu na přístroji.

UPOZORNĚNÍ

Před instalací a používáním zařízení si prostudujte uživatelskou příručku tak,



SEKTION 1: SIKKERHEDSFORANSTALTNINGER

1.0 Sikkerhedsforanstaltninger

Brugere af ESAB svejseudstyr og plasmaskæreudstyr har det endelige ansvar for at til sikre, at enhver, der arbejder på eller tæt ved udstyret, overholder alle relevante sikkerhedsforanstaltninger. Sikkerhedsforanstaltningerne skal overholde de krav, der gælder for denne type svejseudstyr eller plasmaskæreudstyr. Følgende anbefalinger bør følges udover de standardregulativer, der gælder for arbejdsstedet.

Alt arbejde skal udføres af oplært personale, der grundigt kender til betjeningen af svejseudstyret eller plasmaskæreudstyret. Ukorrekt betjening af udstyret kan føre til farlige situationer, som kan resultere i skade på operatøren og beskadigelse af udstyret.

1. Enhver, der bruger svejseudstyr eller plasmaskæreudstyr, skal være fuldt fortrolig med følgende:
 - betjening heraf
 - placering af nødstopkontakter
 - dets funktion
 - relevante sikkerhedsforanstaltninger
 - svejsning og/eller plasmaskæring
2. Operatøren skal sørge for følgende:
 - at der ved opstart af udstyret ikke opholder sig uautoriseret personale indenfor udstyrets arbejdsområde.
 - at ingen er ubeskyttet, når lysbuen tændes.
3. Arbejdsstedet skal:
 - være velegnet til formålet
 - være uden gennemtræk
4. Personligt sikkerhedsudstyr:
 - Brug altid anbefalet, personligt sikkerhedsudstyr så som sikkerhedsbriller, ikke-brændbart tøj og sikkerhedshandsker.
 - Bær ikke løsthængende tøj som tørklæder, brocher, ringe osv., da disse kan sætte sig fast i udstyret eller forårsage forbrænding.
5. Generelle forskrifter:
 - Sørg for at returkablet er grundigt tilsluttet.
 - Kun faglærte elektrikere **må udføre arbejde med udstyr med høj spænding.**
 - Relevant brandslukningsudstyr skal være tydeligt markeret og i umiddelbar nærhed.
 - Smøring og vedligeholdelse af udstyret **må ikke** foretages under betjening.



Indlever elektronisk udstyr på en genbrugsstation!

I henhold til direktiv 2002/96/EF samt national lovgivning om affaldshåndtering af elektrisk og/eller elektronisk udstyr skal udtjent udstyr indleveres på en genbrugsstation for elektrisk og elektronisk udstyr.

Som ansvarlig for udstyret er du efter loven forpligtet til at indhente information om godkendte indsamlingssteder.

For yderligere oplysninger bedes du kontakte din nærmeste ESAB-repræsentant.

ESAB kan levere al nødvendig skærebekyttelse og alt nødvendigt tilbehør.

ESAB CUTMASTER 120

ADVARSEL

SVEJSNING OG PLASMASKÆRING KAN VÆRE SKADELIG FOR DIG SELV OG ANDRE. TAG DINE FORHOLDSREGLER, NÅR DU SVEJSER ELLER SKÆRER. BED DIN ARBEJDSGIVER OM SIKKERHEDSPROCEDURER, SOM BØR VÆRE BASERET PÅ FABRIKANTENS RISIKODATA.

ELEKTRISK STØD - Kan dræbe.

- Montér og jordforbind (jord) svejseudstyret eller plasmaskæreudstyret i overensstemmelse med gældende normer.
- Rør ikke ved de strømførende dele eller elektroderne med den bare hud, våde handsker eller vådt tøj.
- Vær isoleret fra jordforbindelse og arbejdsstykket.
- Sørg for at din arbejdsposition er sikker.

DAMPE OG GASSER - Kan være farlige for helbredet.

- Hold ansigtet væk fra dampene.
- Anvend ventilation, udtræk ved buen, eller begge dele, for at holde dampe og gasser væk fra åndedrætsområdet og omgivelserne i det hele taget.

LYSBUESTRÅLER - Kan beskadige øjne og give forbrændinger på huden.

- Beskyt øjne og krop. Anvend den korrekte svejseværn/plasmaskæreskærm og skærmfilter og hav beskyttelsestøj på.
- Beskyt personer, der står i nærheden, med passende skærme eller forhæng.

BRANDFARE

- Gnister (sprøjt) kan forårsage brand. Derfor skal man sikre sig, at der ikke er brændbare materialer i nærheden.

LARM - Usædvanlig høj larm kan give høreskader.

- Beskyt ørerne. Brug høreværn eller anden hørebeskyttelse.
- Advar personer, der står i nærheden, om risikoen.

FUNKTIONSFEJL - Tilkald eksperthjælp i tilfælde af funktionsfejl.

**LÆS OG FORSTÅ INSTRUKTIONSBOKEN FØR INSTALLATION ELLER BETJENING.
BESKYT DIG SELV OG ANDRE!**

ADVARSEL

Anvend ikke strømkilden til optøning af frosne rør.

FORSIGTIG

Udstyr af "Class A" er ikke beregnet til brug i boliger med strømforsyning fra det almindelige lavspændingsnet. Det kan være problematisk at sikre elektromagnetisk kompatibilitet for udstyr af "Class A" i sådanne lokaler som følge af såvel ledningsbårne som luftbårne forstyrrelser.



FORSIGTIG

Dette produkt er udelukkende beregnet til plasmaskæring. Enhver anden form for anvendelse kan føre til personskade og/eller beskadigelse af udstyr.

FORSIGTIG

Læs og forstå instruktionsbogen før installation eller betjening.



ABSCHNITT 1: SICHERHEIT

1.0 Sicherheitsvorkehrungen

Benutzer von ESAB Schweiß- und Plasmaschneid-ausrüstung haben die Verantwortung sicherzustellen, dass jede an oder in der Nähe der Ausrüstung arbeitende Person sämtliche relevanten Sicherheitsvorkehrungen beachtet. Die Sicherheitsvorkehrungen müssen den auf diese Art von Schweiß- oder Plasmaschneid-ausrüstung anzuwendenden Anforderungen entsprechen. Folgende Empfehlungen sollten zusätzlich zu den sonst am Arbeitsplatz geltenden Regeln beachtet werden. Sämtliche Arbeiten müssen von geschultem Personal, welches mit der Bedienung von Schweiß- oder Plasmaschneid-ausrüstung vertraut ist, ausgeführt werden. Die falsche Bedienung der Ausrüstung kann zu Gefahrsituationen führen, die wiederum zu Verletzungen des Bedieners und Beschädigung der Ausrüstung führen können.

1. Jeder Benutzer von Schweiß- oder Plasmaschneid-ausrüstung muss mit Folgendem vertraut sein:
 - Funktionsweise der Ausrüstung
 - Lage der Notausschalter
 - Betätigung der Notausschalter
 - den relevanten Sicherheitsvorschriften
 - Schweißen und/oder Plasmaschneiden

2. Der Benutzer muss sicherstellen dass:
 - keine unbefugte Person sich beim Anlassen im Arbeitsbereich der Ausrüstung befindet.
 - niemand ungeschützt ist, wenn der Lichtbogen gezündet wird.

3. Der Arbeitsplatz muss:
 - für den Zweck geeignet sein
 - frei von Zugluft sein.

4. Persönliche Schutzausrüstung:
 - Tragen Sie stets eine geeignete persönliche Schutzausrüstung wie eine Schutzbrille, feuersichere Kleidung, Sicherheitshandschuhe.
 - Tragen Sie keine lose hängenden Gegenstände wie Schals, Armbänder, Ringe usw., die sich verfangen oder zu Verbrennungen führen könnten.

5. Allgemeine Sicherheitsvorkehrungen:
 - Stellen Sie sicher, dass das Stromrückleitungskabel richtig angeschlossen ist.
 - Arbeiten an Hochspannungsanlagen **dürfen nur von einem qualifizierten Elektriker** ausgeführt werden.
 - Eine geeignete Feuerlöschanlage muss deutlich gekennzeichnet und in der Nähe sein.
 - Schmierung und Wartung der Ausrüstung **dürfen nicht** während des Betriebs der Ausrüstung ausgeführt werden.



Entsorgen Sie elektronische Ausrüstung in einer Recyclinganlage!

Gemäß EU-Richtlinie 2002/96/EG und nationalen Gesetzgebungen zur Entsorgung elektrischer und bzw. oder elektronischer Ausrüstung müssen Altgeräte in einer Recyclinganlage entsorgt werden.

Als Verantwortlicher für die Ausrüstung sind Sie gesetzlich verpflichtet, Informationen zu autorisierten Sammelstellen einzuholen.

Weitere Informationen erhalten Sie von einem ESAB-Vertreter in Ihrer Nähe.

ESAB bietet sämtliche erforderliche Schweißschutzvorrichtungen und Zubehörkomponenten.

ESAB CUTMASTER 120

WARNUNG	SCHWEISSEN UND PLASMASCHNEIDEN KANN FÜR SIE SELBST UND FÜR ANDERE GEFÄHRLICH SEIN. TREFFEN SIE DESHALB BEIM SCHWEISSEN UND SCHNEIDEN SICHERHEITSVORKEHRUNGEN. FRAGEN SIE IHREN ARBEITGEBER NACH SICHERHEITSMASSNAHMEN, DIE AUF DEN GEFÄHRDUNGSANGABEN DES HERSTELLERS BERUHEN SOLLTEN.
----------------	---

ELEKTRISCHER SCHLAG kann tödlich sein.

- Installieren und erden Sie die Schweiß- oder Plasmaschneideinheit gemäß den gültigen Normen.
- Berühren Sie die elektrischen Teile oder Elektroden nicht mit der nackten Haut, mit nassen Handschuhen oder nasser Kleidung.
- Sorgen Sie für eine ausreichende Isolation zur Erde und dem Werkstück.
- Nehmen Sie eine sichere Arbeitsstellung ein.

RAUCH UND GASE können die Gesundheit gefährden.

- Halten Sie Ihren Kopf nicht in den Rauch.
- Verwenden am Lichtbogen Sie eine Belüftung, einen Abzug oder beides, um den Rauch und die Gase aus Ihrem Atembereich und dem umliegenden Bereich fernzuhalten.

LICHTBOGENSTRAHLEN können zu Augenverletzungen und Hautverbrennungen führen.

- Schützen Sie Ihre Augen und Ihren Körper. Benutzen Sie das richtige Schweiß- bzw. Plasmaschutzschild und Filterlinsen und tragen Sie Schutzkleidung.
- Schützen Sie umstehende Personen mit geeigneten Schilden oder Vorhängen.

FEUERGEFAHR

- Funken (Geprassel) können Brände verursachen. Stellen Sie deshalb sicher, dass keine brennbaren Materialien in der Nähe sind.

LÄRM Exzessiver Lärm kann das Gehör schädigen.

- Schützen Sie Ihre Ohren. Verwenden Sie Ohrenschützer oder anderen Gehörschutz.
- Weisen Sie umstehende Personen auf das Risiko hin.

FUNKTIONSSTÖRUNG Holen Sie sich bei einer Funktionsstörung fachkundige Unterstützung durch einen Experten.

LESEN UND VERSTEHEN SIE DAS BEDIENUNGSHANDBUCH VOR DER INSTALLATION ODER DER INBETRIEBNAHME. SCHÜTZEN SIE SICH UND ANDERE!

WARNUNG	Die Stromquelle darf nicht zum Auftauen gefrorener Rohre eingesetzt werden.
----------------	--

VORSICHT	Geräte der Kategorie "Class A" sind nicht für den Einsatz in Wohnbereichen vorgesehen, deren Stromversorgung an das allgemeine Niederspannungsnetz angeschlossen ist. In diesen Bereichen kann für Geräte der Kategorie "Class A" möglicherweise keine elektromagnetische Verträglichkeit sichergestellt werden, da Störungen in den Leitungen und in der Luft vorliegen.	
-----------------	--	---

VORSICHT	Dieses Produkt darf nur zum Plasmaschneiden verwendet werden. Sämtliche sonstigen Einsätze können zu Körperverletzungen und / oder Geräteschäden führen.
-----------------	---

VORSICHT	Lesen und verstehen sie das bedienungshandbuch vor der	
-----------------	---	---

SECCIÓN 1: PRECAUCIONES DE SEGURIDAD

1.0 Precauciones de seguridad

Los usuarios de los equipos de corte y soldadura ESAB tienen la responsabilidad de garantizar que las personas que trabajan o están cerca del equipo sigan las normas de seguridad.

Las precauciones de seguridad deben ser conformes con equipos de corte y soldadura. Además de las normas estándares, se deben seguir las recomendaciones que se indican a continuación..

1. Toda persona que utilice un equipo de soldadura o corte por plasma debe estar familiarizada con:
 - toda operación
 - localización de los pulsadores de emergencia
 - sus funciones
 - precauciones de seguridad
 - corte plasma y soldadura

2. El operador debe asegurarse de que:
 - ninguna otra persona esté en el área de trabajo durante el arranque de la maquina
 - ninguna persona esté sin protección en el momento del golpe del arco

3. El área de trabajo debe:
 - ser adecuada para la labor
 - estar libre de corrientes de aire

4. Equipo de protección individual:
 - utilice siempre equipos de protección, lentes, prendas ignífugas, guantes, etc.
 - no utilice artículos sueltos, como bufandas, pulseras, anillos, etc.

5. Precauciones generales:
 - asegúrese de que el cable de retorno esta bien conectado
 - el trabajo con alto voltaje debe ser realizado por un técnico cualificado.
 - debe disponerse de un extintor de incendios adecuado cerca de la máquina.
 - no se debe lubricar la máquina durante la operación.



¡Elimine los aparatos electrónicos en una instalación de reciclado!

De conformidad con la Directiva europea 2002/96/CE sobre residuos de aparatos eléctricos y electrónicos y su aplicación con arreglo a la normativa nacional, los aparatos eléctricos o electrónicos que han llegado al final de su vida útil se deben eliminar en una instalación de reciclado.

Como responsable del equipo, le corresponde informarse sobre los puntos de recogida autorizados.

Si desea más información, póngase en contacto con el distribuidor ESAB más cercano.

ESAB puede proporcionarle todos los accesorios y elementos de protección necesarios.

ESAB CUTMASTER 120

ADVERTENCIA

La soldadura y el corte por plasma entraña un peligro de muerte. Adopte las precauciones de seguridad para corte por plasma y soldadura.

LA DESCARGA ELÉCTRICA puede matar.

- Instale un cable de tierra de acuerdo con las normas
- No toque partes eléctricas o consumibles que estén eléctricamente activos.
- Manténgase aislado del piso y de la pieza de trabajo.
- Asegúrese de que el lugar de trabajo sea seguro.

HUMOS Y GASES- Son peligrosos a su salud

- Mantenga la cabeza alejada de los humos
- Utilice ventilación o aspiración para eliminar los humos del área de trabajo.

RAYO DEL ARCO. Puede quemar la piel o dañar los ojos.

- Protéjase los ojos y la piel con lentes y ropa apropiadas.
- Proteja las personas en el área de trabajo utilizando una cortina

PELIGRO DE INCENDIO

- Las chispas pueden provocar un incendio. Asegúrese de que no haya materiales inflamables alrededor de la máquina.

RUIDO – El ruido en exceso puede dañar los oídos.

- Protéjase los oídos. Utilice protección auricular.
- Avise a las personas de alrededor sobre el riesgo.

AVERÍAS – Llame a ESAB en caso de avería en el equipo.

**LEER DETENIDAMENTE EL MANUAL ANTES DE INSTALAR U OPERAR EL EQUIPO.
¡PROTÉJASE A SÍ MISMO Y A LOS DEMÁS!**

ADVERTENCIA

No utilice la unidad de alimentación para descongelar tubos congelados.

PRECAUCIÓN

Los equipos de tipo Class A no están previstos para su uso en lugares residenciales en los que la energía eléctrica proceda de la red pública de baja tensión. En tales lugares puede resultar difícil garantizar la compatibilidad electromagnética de los equipos Class A, debido a las perturbaciones tanto conducidas como radiadas.



PRECAUCIÓN

Este producto está diseñado exclusivamente para el corte por plasma. Cualquier otro uso puede causar daños personales y/o daños al equipo.

PRECAUCIÓN

Leer detenidamente el manual antes de instalar u operar el equipo.



OSA 1: OHUTUS

1.0 Ohutuse Ettevaatusabinõud

Keevitus- ja plasmalõikusseadme ESAB kasutajad omavad lõplikut vastutust kindlustamaks, et kõik, kestõttavad seadmega ja asuvad seadme kõrval, järgivad kõiki vastavaid tööohutuse ettevaatusabinõusid. Ohutuse ettevaatusabinõud peavad vastama nõudeile, mis kehtivad sellist tüüpi keevitus- ja plasmalõikusseadmetele. Järgnevaid soovitusi on vaja järgida lisaks tavalistele reeglitele, mis rakendatakse töökohas.

Kõiki töid võivad teha ainult väljaõppega töötajad, kes tunnevad hästi keevitus- või plasmalõikusseadmete kasutamist. Seadme väärkasutamine võib tekitada ohtlikke olukordi, mille võib olla kasutaja vigastus või seadme rike.

1. Ükskõik, kes kasutab keevitus- ja plasmalõikusseadet, peab tundma:
 - tema tööd
 - avariilülitide asukohti
 - selle funktsioone
 - vastavaid ohutuse ettevaatusabinõusid
 - keevitust ja/või plasmalõikust
2. Kasutaja peab kindlustama:
 - et loata ja mittevajalikud isikuid ei paikneks seadme töötsoonis selle käivitamisel;
 - et kõik kasutavad kaitsevahendeid kaarleegi süttimisel.
3. Töökoht peab:
 - sobima oma eesmärgiks
 - olema vaba tuuletõmbest
4. Isiklikud kaitsevahendid:
 - Alati peab kandma soovitatavaid isiklikuid kaitsevahendeid, nagu näiteks kaitseprille, tulekindlaid kaitseriideid ja sobivaid kindaid.
 - Ärge kandke liiga lahtisi rõivaid ega esemeid, nagu näiteks salle, käevõrusid, jne. Nende seadmete vahele sattumise tulemuseks on kehavigastus või põletus.
5. Üldised ettevaatusabinõud:
 - Tuleb kindlustada tagasipöörduva kaabli turvaline ühendus.
 - Töid kõrgepingeseadmetega **võib teostada ainult kvalifitseeritud elektrik.**
 - Vastavad tulekustutamisseaded peavad olema silmnähtavalt märgistatud ja paiknema ligidal.
 - Seadme määrimist ja hooldust **ei tohi** teostada seadme kasutamise ajal.



Kõrvaldage elektroonikaseadmed ringlussevõturajatises!

Järgides Euroopa direktiivi 2002/96/EÜ elektri- ja elektroonikaseadmete jäätmete kohta ja selle rakendamist siseriikliku õiguse kohaselt, tuleb kasutuskõlbmatuks muutunud elektrija/või elektroonikaseadmed kõrvaldada ringlussevõturajatises.

Seadmete eest vastutava isikuna on Teie kohustuseks hankida teavet volitatud kogumisjaamade kohta. Lisateabe saamiseks pöörduge lähima ESAB'i toodete edasimüüja poole.

ESAB varustab teid kõigi lõikamisel vajalike kaitsevahendite ja tarvikutega.

ESAB CUTMASTER 120

HOIATUS	KEEVITUS JA PLASMALÕIKUS VÕIVAD TEKITADA KEHAVIGASTUSI TEILE JA TEISTELE. VÕTKE TARVITUSELE ETTEVAATUSABINÕUSID KEEVITAMISE JA LÕIKUSE AJAL. KÜSIGE OMA TÖÖ- ANDJALT TEAVET OHUTUTE TÖÖVÕTETE KOHTA MIS PÕHINEB TOOTJALT SAADUD INFORMATSIOONIL OHTUDEST SEADMEGA TÖÖTAMISEL.
----------------	--

Elektrilöök - võib tappa!

- Paigaldage ja maandage keevituse või plasmalõikuse seade vastavalt kohaldatavatele reeglitele.
- Ärge puudutage voolu all olevaid osi paljaste kätega, niiskete kinnastega või niiskete rõivastega.
- Isoleerige end maast ja töödeldavast detailist.
- Töötamise ajal hoidke end ohutus kehaasendis.

SUIJS JA GAASID - on kahjulikud teie tervisele.

- Hoidke pea eemal suitsust.
- Kasutage ventilatsiooni või õhutõmmet või mõlemaid suitsu ja gaaside eemaldamiseks hingamispiirkonnast ja tööruumist.

KAARE KIIRGUS - võib vigastada silmi ja põletada nahka.

- Kaitske oma silmi ja keha. Kasutage keevituse/plasmalõikuse kaitseekraani ja keevitusmaski ja kandke kaitseriideid.
- Kaitske kõrvalseisjaid sobivate ekraanidega ja sirmidega.

TULEOHT

- Sädemed võivad tekitada tulekahju. Veenduge, et lähedal ei ole kergsüttivaid materjale.

MÜRA - liigne müra võib kahjustada kuulmist.

- Kaitske oma kõrvu. Kasutage kaitsekõrvaklappe või teisi kaitsevahendeid.
- Hoiatage kõrvalolijaid ohust.

RIKE - juhul kui esineb rike, kutsuge asjatundja.

ENNE SEADME PAIGALDAMIST VÕI KASUTAMIST LUGEGE KASUTUSJUHEND LÄBI JA VEENDUGE, ET OLETE SELLEST ARU SAANUD. KAITSKE END JA TEISI!

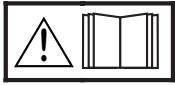
HOIATUS	Ärge kasutage energiaallikat külmunud torude sulatamiseks.	
TÄHELEPANU	Class A seadmed ei ole mõeldud kasutamiseks elumajades, kus elektrivoolu saadakse avalikust madalpingevõrgust. Neis kohtades võib esineda raskusi Class A seadmete elektromagnetilise ühilduvuse tagamisel juhtivuslike või kiiruslike häiringute tõttu.	
TÄHELEPANU	See seade on üksnes plasmalõikuseks. Mis tahes muu kasutus võib põhjustada kehavigastusi ja/või kahjustada seadet.	
TÄHELEPANU	Enne seadme paigaldamist või kasutamist lugege kasutusjuhend läbi ja veenduge.	

KAPPALE 1: TURVATOIMET

1.0 Turvatoimet

ESABin hitsaus- ja plasmaleikkuuvälineiden käyttäjät vastaavat viime kädessä siitä, että tuotteen käyttäjät tai tuotteen lähellä työskentelevät noudattavat turvallisuusohjeita. Turvallisuusohjeiden on oltava tämäntyyppisten hitsaus- tai plasmaleikkuuvälineiden vaatimusten mukaisia. Seuraavat suositukset on otettava huomioon työpaikan normaalien säännösten lisäksi. Kaikki työt on jätettävä koulutetulle henkilöstölle, joka tuntee hitsaus- tai plasmaleikkuuvälineiden toiminnan.

Laitteiston väärä käyttötapa voi johtaa vaaratilanteisiin, jotka voivat puolestaan johtaa käyttäjän loukkaantumiseen ja laitteiston vaurioitumiseen.

1. Hitsaus- tai plasmaleikkuuvälineen käyttäjän on tunnettava:
 - laitteen toiminta
 - hätäkatkaisinten sijainti
 - koneen toiminta
 - turvallisuusohjeet
 - hitsaaminen ja/tai plasmaleikkaaminen.
2. Käyttäjän on varmistettava, että:
 - laitteen lähellä ei ole valtuuttamattomia henkilöitä käynnistyshetkellä.
 - kaikilla on suojat, kun kaari muodostetaan.
3. Työpaikan on:
 - sovittava tarkoitukseen
 - oltava vedoton.
4. Henkilökohtaiset suojaruusteet:
 - Käytä aina suositeltuja henkilökohtaisia suojaruusteita, kuten suojalaseja, tulenkestäviä vaatteita ja turvakäsineitä.
 - Älä käytä löysiä asusteita, kuten huiveja, koruja, sormuksia jne., jotka voivat juuttua kiinni tai aiheuttaa palovammoja.
5. Yleiset varoimenpiteet:
 - Varmista, että paluukaapeli on kytketty oikein.
 - Suurjännitelaitteita saa huoltaa vain valtuutettu sähköasentaja.
 - Asianmukaisten sammutusvälineiden on oltava selkeästi merkittyjä ja helposti saatavilla.
 - Laitteistoa ei saa voidella tai huoltaa käytön aikana.



Vie elektroniikkalaitteet keräyspisteeseen!

Sähkö- ja elektroniikkaromua (SER) koskevan direktiivin 2002/96/EY ja kansallisen lainsäädännön mukaan hävitettävät laitteet tulee viedä keräyspisteeseen.

Laitteesta vastaavana henkilönä olet lain mukaan velvollinen selvittämään hyväksytyt keräyspisteet.

Lisätietoja saat ESAB-edustajaltasi.

ESAB tarjoaa sinulle kaikki tarvittavat suojaruusteet ja tarvikkeet.

ESAB CUTMASTER 120

VAROITUS	HITSAAMINEN JA PLASMALEIKKAAMINEN VOI OLLA VAARALLISTA ITSELLESI JA MUILLE. NOUDATA TURVALLISUUSOHJEITA, KUN HITSAAT TAI LEIKKAAT. KYSY TYÖNANTAJAN TURVAOHJEITA, JOIDEN ON PERUSTUTTAVA VAARATIETOIHIN.
-----------------	---

SÄHKÖISKU voi tappaa.

- Asenna ja maadoita hitsaus- tai plasmaleikkauslaite asianmukaisten standardien mukaan.
- Älä kosketa jännitteisiä sähköosia tai elektrodeja paljaalla iholla, märillä hansikkailla tai märillä vaatteilla.
- Eristä itsesi maadoituksesta ja työkappaleesta.
- Varmista, että työasentosi on turvallinen.

HÖYRYT JA KAASUT voivat olla vaarallisia terveydelle.

- Pidä pää poissa höyryistä.
- Poista höyryt ja kaasut hengitysalueelta ja työalueelta ilmanvaihdon tai polttimeen imulaitteiston avulla.

KAAREN SÄTEET voivat vaurioittaa silmiä ja aiheuttaa palovammoja.

- Suojaa silmäsi ja kehosi. Käytä oikeaa hitsauksen/plasmaleikkauksen suojusta ja suodatinlinssiä ja käytä suojavaatetusta.
- Suojaa sivulliset sopivilla suojuksilla tai verhoilla.

PALOVAARA

- Kipinät (roiskeet) voivat aiheuttaa tulipalon. Varmistu siitä, ettei lähellä ole herkästi syttyviä materiaaleja.

MELU - Liiallinen melu voi vaurioittaa kuuloa.

- Suojaa korvat. Käytä korvatulppia tai muita kuulonsuojaimia.
- Varoita sivullisia vaarasta.

TOIMINTAHÄIRIÖ - Pyydä asiantuntija-apua toimintahäiriön sattuessa.

LUE JA SISÄISTÄ OHJEET ENNEN ASENNUSTA JA KÄYTTÖÄ.

SUOJAA MUUT JA ITSESI!

VAROITUS	Viralähdettä ei saa käyttää jäätynneiden putkien sulattamiseen.
-----------------	--

VARO	Class A-laitetta ei ole tarkoitettu käytettäväksi asunnoissa, joiden virransyöttö tapahtuu yleisestä pienjänniteverkosta. "Class A"-laitteen sähkömagneettista yhteensopivuutta voi olla vaikea varmistaa sellaisissa asunnoissa sekä johtojen että ilman kautta kulkeutuvien häiriöiden takia.	
-------------	--	---

VARO	Tämä tuote on tarkoitettu vain plasmaleikkaukseen. Mikä tahansa muu käyttö voi aiheuttaa henkilövahinkoja ja/tai laitevaurioita.
-------------	---

VARO	Lue ja sisäistä ohjeet ennen asennusta ja käyttöä.	
-------------	---	---

CHAPITRE 1 : SÉCURITÉ

1.0 Précautions de sécurité

Les utilisateurs du matériel de soudage et de coupage plasma ESAB ont la responsabilité ultime d'assurer que toute personne qui utilise ou qui se trouve dans l'aire de travail observe l'ensemble des précautions de sécurité pertinentes. Celles-ci doivent répondre aux exigences applicables à ce type de matériel de soudage ou de coupage plasma. Les recommandations suivantes doivent être observées en plus des règles standard qui s'appliquent au lieu de travail.

Tous les travaux doivent être effectués par un personnel qualifié connaissant bien le fonctionnement du matériel de soudage et de coupage plasma. Un fonctionnement incorrect du matériel peut créer des dangers susceptibles de causer des blessures à l'opérateur d'endommager le matériel au matériel.

1. Toute personne travaillant avec le matériel de soudage ou de coupage plasma doit connaître :
 - son fonctionnement ;
 - l'emplacement des interrupteurs d'arrêt d'urgence ;
 - sa fonction ;
 - les précautions de sécurité pertinentes ;
 - les procédures de soudage et/ou de coupage plasma.

2. L'opérateur doit s'assurer que :
 - seules les personnes autorisées à travailler sur l'équipement se trouvent dans l'aire de travail lors de la mise en marche de l'équipement ;
 - toutes les personnes se trouvant sur l'aire de travail sont protégées lorsque l'arc est amorcé.

3. Le lieu de travail doit être :
 - adapté aux opérations effectuées ;
 - dénué de courants d'air de courants d'air.

4. Équipement de sécurité personnelle
 - Toujours utiliser des équipements de sécurité adaptés tels que des lunettes de protection, des vêtements à l'épreuve des flammes et des gants de protection.
 - Ne jamais porter de vêtements amples, tels que des foulards, ou encore des bagues, etc., qui pourraient se prendre dans l'appareil ou causer des brûlures.

5. Précautions générales :
 - Assurez-vous que le câble de retour est bien branché.
 - Les équipements haute tension doivent être manipulés par un électricien qualifié uniquement.
 - Un équipement d'extinction d'incendie approprié doit se trouver à proximité de l'appareil, à un emplacement indiqué de manière claire.
 - Ne jamais procéder à la lubrification ou à la maintenance du matériel lorsque l'appareil est en marche.



Disposer d'un équipement électronique à l'installation de recyclage!

En respect de la Directive européenne 2002/96/CE relative aux déchets d'équipements électriques et électroniques et sa mise en œuvre conformément à la loi nationale, électrique et/ou de l'équipement électronique qui a atteint la fin de sa durée de vie doivent être éliminés dans une installation de recyclage.

Comme la personne responsable de l'équipement, il est de votre responsabilité d'obtenir des informations sur approuvées stations de collecte.

Pour de plus amples renseignements, communiquez avec votre distributeur ESAB.

ESAB peut vous fournir avec toutes les coupes nécessaires protection et accessoires.

ESAB CUTMASTER 120

AVERTISSEMENT

LE SOUDAGE ET LE COUPAGE À L'ARC PEUVENT CAUSER DES BLESSURES À L'OPÉRATEUR OU AUX AUTRES PERSONNES SE TROUVANT DANS L'AIRE DE TRAVAIL. ASSUREZ-VOUS DE PRENDRE TOUTES LES PRÉCAUTIONS NÉCESSAIRES LORS DES OPÉRATIONS DE SOUDAGE OU DE COUPAGE. DEMANDEZ À VOTRE EMPLOYEUR UNE COPIE DES MESURES DE SÉCURITÉ QUI DOIVENT ÊTRE ÉLABORÉES À PARTIR DES DONNÉES DES RISQUES DU FABRICANT.

CHOC ÉLECTRIQUE - peut être mortel.

- Assurez-vous que l'unité de soudage ou de coupage plasma est installée et mise à la terre conformément aux normes applicables.
- Ne pas toucher les pièces électriques sous tension ou les électrodes si vos mains ne sont pas bien protégées ou si vos gants ou vos vêtements sont humides.
- Assurez-vous que votre corps est bien isolé de la mise à la terre et de la pièce à traiter.
- Assurez-vous que votre position de travail est sûre.

VAPEURS ET GAZ - peuvent être dangereux pour la santé.

- Gardez votre tête éloignée des vapeurs.
- Utilisez un système de ventilation et/ou d'extraction à l'arc pour évacuer les vapeurs et les gaz de votre zone respiratoire et plus généralement, de l'aire de travail..

RAYONS DE L'ARC - peuvent endommager la vue ou brûler la peau.

- Protégez vos yeux et votre corps. Utilisez un écran de soudage/coupage plasma ainsi que des lunettes teintées adaptés, et portez des vêtements de protection.
- Protégez les personnes se trouvant dans l'aire de travail à l'aide d'un écran ou d'un rideau protecteur adapté.

RISQUE D'INCENDIE

- Les étincelles (projections) peuvent causer un incendie. Assurez-vous qu'il n'y a pas de matériel inflammable à proximité de l'appareil.

BRUIT - un bruit excessif peut endommager la capacité auditive.

- Protégez vos oreilles. Utilisez des protecteurs d'oreilles ou un autre type de protection auditive.
- Avertissez les personnes se trouvant dans l'aire de travail de ce risque.

MAUVAIS FONCTIONNEMENT - en cas de mauvais fonctionnement, demandez l'aide d'une personne qualifiée.

ASSUREZ-VOUS DE LIRE ET DE COMPRENDRE LE MANUEL D'UTILISATION AVANT D'INSTALLER OU D'UTILISER L'UNITÉ. PROTÉGEZ-VOUS ET LES AUTRES !

AVERTISSEMENT

Ne pas utiliser le générateur pour dégeler des canalisations.

ATTENTION

Les équipements de "Class A" ne sont pas conçus pour un usage résidentiel alimenté par de la basse tension. Dans ce cas, des problèmes de compatibilité électromagnétique des équipements de "Class A" peuvent se produire en raison de perturbations liées à la conduction et au rayonnement.

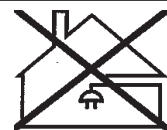

ATTENTION

Ce produit est destiné au coupage plasma uniquement. Toute autre utilisation peut entraîner des blessures ou endommager l'équipement.

ATTENTION

Assurez-vous de lire et de comprendre le manuel d'utilisation avant

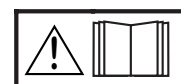

1. DIO SIGURNOSNE MJERE OPREZA

1.0 Sigurnosne mjere opreza

Krajnja je odgovornost korisnika ESAB opreme za zavarivanje i rezanje plazmom osigurati da se svi koji rade na ili u blizini opreme pridržavaju svih primjenjivih sigurnosnih mjera opreza. Sigurnosne mjere opreza moraju udovoljavati zahtjevima koji se primjenjuju na ovu vrstu opreme za zavarivanje ili rezanje plazmom. Osim standardnih propisa koji se primjenjuju na radnom mjestu, treba poštivati sljedeće preporuke.

Sve radove mora izvoditi obučeno osoblje dobro upoznato s radom opreme za zavarivanje ili rezanje plazmom. Neispravan rad opremom može dovesti do opasnih situacija koje mogu imati za posljedicu ozljedu operatora i oštećenje opreme.

1. Svi koji koriste opremu za zavarivanje ili rezanje plazmom moraju poznavati:
 - njezin rad
 - mjesto prekida rada u slučaju opasnosti
 - njezinu funkciju
 - primjenjive sigurnosne mjere opreza
 - zavarivanje i/ili rezanje plazmom
2. Operator mora osigurati da:
 - nema neovlaštenih osoba unutar radnog prostora opreme u trenutku započinjanja rada.
 - nitko nije nezaštićen u trenutku pokretanja luka.
3. Radno mjesto mora:
 - odgovarati namjeni
 - ne smije biti na propuhu
4. Oprema za osobnu sigurnost:
 - Uvijek nosite preporučenu opremu za osobnu sigurnost kao što su sigurnosne naočale, odjeća otporna na plamen, sigurnosne rukavice.
 - Ne nosite slabo pričvršćene predmete kao što su šalovi, narukvice, prstenje itd. koji bi mogli zapeti ili izazvati opekline.
5. Opće mjere opreza:
 - Provjerite je li povratni kabel čvrsto spojen.
 - Radove na visokonaponskoj opremi **može izvoditi samo kvalificirani električar.**
 - Odgovarajuća oprema za gašenje požara mora biti jasno označena i nalaziti se u blizini.
 - Podmazivanje i održavanje **ne smije se** izvoditi na opremi tijekom rada.



Elektroničku opremu odstranite u reciklažnom postrojenju!

U skladu s Europskom Direktivom 2012/19/EU o otpadnoj električnoj i elektroničkoj opremi i njenom primjenom u skladu s nacionalnim zakonom električna i/ili elektronička roba kojoj je istekao uporabni vijek mora se zbrinuti u reciklažnom postrojenju.

Kao osoba odgovorna za opremu dužni ste nabaviti informacije o ovlaštenim sakupljačkim stanicama.

Za dodatne informacije obratite se najbližem distributeru tvrtke ESAB.

Tvrtka ESAB osigurava vam svu potrebnu zaštitu za zavarivanje i dodatnu opremu.

ESAB CUTMASTER 120

UPOZORENJE	ZAVARIVANJEM I REZANJEM PLAZMOM MOŽETE OZLIJEDITI SEBE I DRUGE. PODUZMITE MJERE OPREZA KAD ZAVARUJETE ILI REŽETE. ZATRAŽITE OD POSLODAVCA SIGURNOSNE POSTUPKE KOJI SE MORAJU ZASNIVATI NA PODACIMA O OPASNOSTI KOJE JE DAO PROIZVOĐAČ.
-------------------	---

ELEKTRIČNI UDAR - može ubiti.

- Montirajte i uzemljite uređaj za zavarivanje ili rezanje plazmom u skladu s primjenjivim standardima.
- Ne dodirujte električne dijelove pod naponom ili elektrode golom kožom, mokrim rukavicama ili odjećom.
- Izolirajte se od tla i predmeta obrade.
- Uvjerite se da je vaš radni položaj siguran.

ISPARAVANJA I PLINOVI - mogu biti opasni po zdravlje.

- Držite glavu podalje od isparavanja.
- Koristite se ventilacijom, izvlačenjem luka ili oboje kako bi udaljili isparavanja i plinove od područja disanja i općeg područja rada.

ZRAKE LUKA - mogu ozlijediti oči i opeći kožu.

- Zaštitite oči i tijelo. Koristite odgovarajući zaslon za zavarivanje/rezanje plazmom i štitnik i nosite zaštitnu odjeću.
- Zaštitite promatrače odgovarajućim zaslonom ili zastorom.

OPASNOST OD POŽARA

- Iskre (prskanje) mogu izazvati požar. Zato osigurajte da u blizini nema zapaljivih materijala.

BUKA - Prekomjerna buka može oštetiti sluh.

- Zaštitite uši. Koristite štitnike za uši ili drugu zaštitu za sluh.
- Upozorite promatrače na rizik.

NEISPRAVAN RAD - Potražite stručnu pomoć u slučaju neispravnog rada.

PROČITAJTE I UVJERITE SE DA RAZUMIJETE UPUTE ZA UPORABU PRIJE MONTAŽE ILI RADA. ZAŠTITITE SEBE I DRUGE!

UPOZORENJE	Izvor napajanja nemojte koristiti za topljenje zamrznutih cijevi.
-------------------	---

OPREZ	Oprema klase A nije namijenjena za korištenje u stambenim prostorima u kojima se električna energija isporučuje javnim niskonaponskim sustavom. U tim prostorima postoje potencijalni problemi osiguravanja elektromagnetske kompatibilnosti opreme klase A zbog vođenih i zračenih smetnji.	
--------------	--	---

OPREZ	Ovaj proizvod je namijenjen isključivo za rezanje plazmom. Uporaba za bilo koju drugu svrhu može prouzročiti osobne ozljede i/ili oštećenja opreme.
--------------	---

OPREZ	Pročitajte i uvjerite se da razumijete upute za uporabu prije montaže ili rada.	
--------------	---	---

1. SZAKASZ: Biztonsági

1.0 Biztonsági óvintézkedések

Az ESAB hegesztő- és plazmaíves vágókészülékek működtetőinek felelőssége annak biztosítása, hogy a készülék közelében dolgozók betartsák a vonatkozó biztonsági utasításokat. A biztonsági utasításoknak meg kell felelniük az ilyen típusú hegesztő- vagy plazmaíves vágókészülékekre vonatkozó követelményeknek. A munkahelyen érvényes általános szabályozáson kívül a következő ajánlásokat is be kell tartani.

Mindenfajta munkát olyan képzett személynek kell végeznie, aki jól ismeri a hegesztő- és plazmaíves vágókészülékek működését. A készülék helytelen működtetése olyan veszélyes helyzetet eredményezhet, amely a berendezés működtetőjének sérülését okozhatja, illetve kárt tehet a berendezésben.

1. A hegesztő- vagy plazmaíves vágókészüléket működtetőjének ismernie kell a következőket:
 - a készülék működését
 - a vészleállító kapcsolók elhelyezkedését
 - azok működését
 - a vonatkozó biztonsági óvintézkedéseket
 - hegesztést és / vagy plazmaíves vágást
2. A működtetőnek biztosítani kell a következőket:
 - nem tartózkodik jogosulatlan személy a készülék környezetében annak indításakor
 - senki nem marad védelem nélkül az ív begyulladás után
3. A munkahely követelményei:
 - a célnak való alkalmasság
 - huzatmentes környezet
4. Személyi védőfelszerelés:
 - Mindig viseljen olyan védőfelszerelést, mint védőszemüveg, tűzálló ruházat, védőkesztyű.
 - Ne viseljen olyan szabadon álló kellékeket, mint sál, karkötő, gyűrű, stb., amelyek beszorulhatnak, vagy égési sérüléseket okozhatnak.
5. Általános óvintézkedések:
 - Győződjön meg arról, hogy a vezeték biztosan van rögzítve.
 - Magasfeszültségű készüléken **kizárólag képzett villanyszerelő végezhet munkálatokat.**
 - Megfelelő tűzoltó készüléknek kell lennie a közelben, egyértelműen megjelölt helyen.
 - Kenési és karbantartási munkálatok végzése **tilos** a készüléken működés közben.



Az elektromos berendezéseket újrahasznosító létesítményben helyezze el!

Az elektromos és elektronikus berendezések hulladékairól szóló 2002/96/EK irányelvre és/vagy elektronikus berendezéseket hasznos élettartamuk leteltével újrahasznosító létesítményben kell elhelyezni.

Miután ön felel a berendezéseket, az ön feladata, hogy tájékoztatást szerezzen a jóváhagyott begyűjtőhelyekről.

További tájékoztatásért forduljon a legközelebbi ESAB forgalmazóhoz.

Az ESAB minden hegesztéshez szükséges védőeszközt és kiegészítőt kínál.

ESAB CUTMASTER 120

VIGYÁZAT	A HEGESZTÉS ÉS PLAZMAÍVES VÁGÁS AZ ÖN ÉS MÁSOK SÉRÜLÉSÉT OKOZHATJÁK. TEGYEN ÓVINTÉZKEDÉSEKET HEGESZTÉSKOR ÉS VÁGÁSKOR. HASZNÁLJA MUNKÁLTATÓJÁNAK BIZTONSÁGI ELŐÍRTÁSAIT, AMELYEKNEK A GYÁRTÓ BIZTONSÁGI ADATAIN KELL ALAPULNIUK.
-----------------	---

ÁRAMÜTÉS - halálos kimenetelű lehet.

- A hegesztő vagy plazmaíves vágókészüléket az alkalmazható szabványoknak megfelelően szerelje össze, és lássa el földeléssel.
- Ne érintse a készülék elektromos részeit vagy elektródáit bőrhöz, nedves kesztyűhöz vagy ruhához.
- Szigetelje magát a földeléstől és a munkadarabtól.
- Győződjön meg arról, hogy biztonságos munkatávolságban van.

FÜST ÉS GÁZ - egészségre káros lehet.

- Tartsa fejét füstöktől távol.
- Használjon szellőztetést, légelszívást (vagy mindkettőt) az ív helyén a gázok eltávolítására a légzési és az általános területről.

ÍVSUGARAK - szem- és bőrsérüléseket okozhatnak.

- Óvja szemét és testét. Viseljen megfelelő hegesztő- / plazmavágó pajzsot és lencsét, illetve viseljen megfelelő védőruházatot.
- Védje a berendezés közelében állókat megfelelő válaszfalal vagy függönnyel.

TŰZVESZÉLY



- A szikrák (fröccsenés) tüzet okozhatnak. Ezért gondoskodjon arról, hogy ne legyen a közelben gyúlékony anyag..

ZAJ - a túlzott zaj károsíthatja a hallást.

- Védje a fülét. Viseljen fülvédő vagy egyéb hallásvédő készüléket.
- Figyelmeztesse a veszélyre a berendezés közelében állókat.

MEGHIBÁSODÁS - meghibásodás esetén hívjon szakavatott segítséget.

**AZ ÖSSZESZERELÉS ÉS MŰKÖDTETÉS ELŐTT OLVASSA EL A HASZNÁLATI ÚTMUTATÓT.
VÉDJE ÖNMAGÁT ÉS MÁSOKAT!**

VIGYÁZAT	Ne használja a hegesztő berendezést befagyott csövek kiolvasztására!	
FIGYELEM	"Class A" osztályú berendezés nem használható lakókörnyezetben, ahol a tápellátás a kiefeszültségű hálózaton keresztül biztosított. A vezetett, valamint a sugárzott zavarás következtében ezeken a helyeken potenciális nehézséget okozhat "Class A" osztályú berendezés elektromágneses kompatibilitásának biztosítása.	
FIGYELEM	A termék kizárólag plazmaíves vágásra használható. Az eltérő használat személyi sérülést és / vagy anyagi kárt okozhat.	
FIGYELEM	Az összeszerelés és működtetés előtt olvassa el a használati útmutatót.	

SEZIONE 1: SICUREZZA

1.0 Indicazioni per la sicurezza

Gli utenti dell'attrezzatura per la saldatura e il taglio al plasma ESAB hanno la responsabilità di accertarsi che chiunque lavori con il dispositivo o accanto ad esso adotti tutte le idonee misure di sicurezza. Le misure di sicurezza devono soddisfare i requisiti che si applicano a questo tipo di dispositivo per la saldatura o il taglio al plasma. Attenersi alle seguenti raccomandazioni, oltre che ai regolamenti standard che si applicano al luogo di lavoro. Tutto il lavoro deve essere eseguito da personale addestrato, perfettamente al corrente del funzionamento dell'attrezzatura per la saldatura o il taglio al plasma. L'utilizzo errato dell'attrezzatura può determinare situazioni pericolose con conseguenti lesioni all'operatore e danni al dispositivo stesso.

1. Chiunque utilizzi attrezzature per la saldatura o il taglio al plasma deve conoscerne perfettamente:
 - il funzionamento
 - la posizione degli arresti di emergenza
 - la funzione
 - le idonee misure di sicurezza
 - la saldatura e/o il taglio al plasma
2. L'operatore deve accertarsi che:
 - nessuna persona non autorizzata si trovi nell'area operativa dell'attrezzatura quando questa viene messa in funzione.
 - tutti siano protetti quando si accende l'arco.
3. Il luogo di lavoro deve essere:
 - idoneo allo scopo
 - privo di correnti d'aria
4. Dispositivi di protezione individuale:
 - indossare sempre i dispositivi di protezione individuale raccomandati, come occhiali di sicurezza, abbigliamento ignifugo, guanti di sicurezza.
 - non indossare indumenti larghi o accessori,, come sciarpe, braccialetti, anelli, ecc., che potrebbero rimanere intrappolati o causare ustioni.
5. Precauzioni generali:
 - accertarsi che il cavo di ritorno sia collegato saldamente;
 - il lavoro su apparecchiature ad alta tensione **può essere effettuato solo da parte di tecnici qualificati;**
 - i dispositivi antincendio idonei devono essere indicati chiaramente e a portata di mano;
 - durante il funzionamento non effettuare lavori di lubrificazione e manutenzione.



Dispose of electronic equipment at the recycling facility!

In observance of European Directive 2002/96/EC on Waste Electrical and Electronic Equipment and its implementation in accordance with national law, electrical and/or electronic equipment that has reached the end of its life must be disposed of at a recycling facility.

As the person responsible for the equipment, it is your responsibility to obtain information on approved collection stations.

For further information contact the nearest ESAB dealer.

ESAB è in grado di fornire tutte le necessarie taglie protezione e accessori.

ESAB CUTMASTER 120

AVVERTENZA	LA SALDATURA E IL TAGLIO AL PLASMA POSSONO ESSERE PERICOLOSI PER L'OPERATORE E COLORO CHE GLI SI TROVANO ACCANTO. ADOTTARE LE OPPORTUNE PRECAUZIONI DURANTE LA SALDATURA O IL TAGLIO. RICHIEDERE AL PROPRIO DATORE DI LAVORO INFORMAZIONI SULLE MISURE DI SICUREZZA ADOTTATE, CHE SI DEVONO BASARE SUI DATI RELATIVI AL PERICOLO INDICATI DAL PRODUTTORE.
-------------------	--

SCOSSA ELETTRICA - Può essere mortale

- Installare e collegare a terra (massa) l'unità di saldatura o taglio al plasma in conformità alle norme applicabili.
- Non toccare le parti elettriche o gli elettrodi sotto tensione con la pelle nuda e guanti o abbigliamento bagnato.
- Isolarsi dalla terra e dal pezzo in lavorazione.
- Accertarsi che la propria posizione di lavoro sia sicura.

FUMI E GAS - Possono essere pericolosi per la salute.

- Tenere la testa lontano dai fumi.
- Usare la ventilazione, l'estrazione fumi sull'arco o entrambe per mantenere lontani fumi e gas dalla propria zona di respirazione e dall'area in genere.

I RAGGI DELL'ARCO - Possono causare lesioni agli occhi e ustionare la pelle.

- Proteggere gli occhi e il corpo. Usare lo schermo di protezione per saldatura/taglio al plasma e lenti con filtro idonei e indossare abbigliamento di protezione.
- Proteggere le persone circostanti con schermi o barriere di sicurezza idonee.

PERICOLO DI INCENDIO

- Scintille (spruzzi) possono causare incendi. Accertarsi quindi che nelle immediate vicinanze non siano presenti materiali infiammabili.

RUMORE - Il rumore in eccesso può danneggiare l'udito.

- Proteggere le orecchie. Usare cuffie antirumore o altre protezioni per l'udito.
- Informare le persone circostanti del rischio.

GUASTI - In caso di guasti richiedere l'assistenza di un esperto.

NON INSTALLARE NÉ UTILIZZARE L'ATTREZZATURA PRIMA DI AVER LETTO E COMPRESO IL MANUALE DI ISTRUZIONI. PROTEGGERE SE STESSI E GLI ALTRI!

AVVERTENZA	Non utilizzare la fonte di alimentazione per lo scongeli tubi.
-------------------	---

ATTENZIONE	Questa apparecchiatura di Classe A non è destinata all'utilizzo in siti residenziali nei quali l'elettricità provenga da un sistema di alimentazione pubblico a bassa tensione. In tali siti può essere difficile assicurare la compatibilità elettromagnetica, a causa delle interferenze condotte e irradiate.	
-------------------	---	---

ATTENZIONE	Questo prodotto è destinato esclusivamente al taglio del plasma. Qualsiasi altro utilizzo potrebbe provocare lesioni personali e/o danni alle apparecchiature.
-------------------	---

ATTENZIONE	Non installare né utilizzare l'attrezzatura prima di aver letto e compreso	
-------------------	---	---

1 SKYRIUS. ATSARGUMO PRIEMONĖS

1.0 Atsargumo priemonės

ESAB virinimo ir plazminio pjaustymo įrangos naudotojai yra visiškai atsakingi už tai, kad užtikrintų, jog visi, dirbantys su ar šalia įrangos, laikosi visų atsargumo priemonių. Atsargumo priemonės turi atitikti reikalavimus, taikomus šio tipo virinimo ar plazminio pjaustymo įrangai. Be standartinių nuostatų, taikomų darbo vietoje, reikia atsižvelgti ir į šias rekomendacijas.

Visą darbą turi atlikti išmokytas personalas, kuris yra gerai susipažinęs su virinimo ar plazminio pjaustymo įrangos eksploatavimu. Netinkamai naudojant įrangą gali įvykti nelaimingi atsitikimai, kurių metu operatorius gali susižaloti bei sugadinti įrangą.

1. Visi, naudojantys virinimo ar plazminio pjaustymo įrangą, turi susipažinti su:
 - jos veikimo principais;
 - avarinių stabdiklių vieta;
 - jos funkcijomis;
 - atitinkamomis atsargumo priemonėmis;
 - suvirinimu ir (arba) plazminiu pjaustymu.
2. Operatorius turi užtikrinti, kad:
 - paleidus įrangą darbo vietoje nebūtų nė vieno neįgalio asmens;
 - paleidus arką nė vienas nėra be apsauginių priemonių.
3. Darbo vieta turi būti:
 - tinkama tam tikslui;
 - nesausa.
4. Asmeninė apsauginė įranga:
 - visada dėvėkite rekomenduojamą asmeninę apsaugos įrangą, pvz., apsauginius akinius, ugniai atsparius drabužius, apsaugines pirštines;
 - nedėvėkite laisvai kabančių aksesuarų, pvz., šalikų, apyrankių, žiedų ir t. t., kurie gali užkliūti arba sukelti nudegimus.
5. Bendros atsargumo priemonės:
 - patikrinkite, ar grįžtamasis kabelis patikimai pritvirtintas;
 - su aukštos įtampos įranga dirbti gali tik kvalifikuotas elektrikas;
 - atitinkama gaisro gesinimo įranga turi būti aiškiai pažymėta ir lengvai pasiekiamą;
 - įrangos sutepimas ir apžiūra neturi būti atliekama eksploatavimo metu.



Nebenaudojamą elektroninę įrangą pateikite perdirbimo įmonei!

Pagal Europos Direktyvą 2002/96/EB dėl elektrinių ir elektroninių atliekų ir jos pritaikymą pagal nacionalinius įstatymus, nebetinkama naudoti elektros ir (arba) elektroninė įranga turi būti pateikta perdirbimo įmonei.

Esate už įrangą atsakingas asmuo, todėl įsipareigojate gauti informacijos apie patvirtintas surinkimo stotis.

Dėl išsamesnės informacijos kreipkitės į artimiausią ESAB platintoją.

ESAB gali pateikti visas reikalingas suvirinimo apsaugas ir priedus.

ESAB CUTMASTER 120

ĮSPĖJIMAS	ATLIKDAMI VIRINIMĄ IR PLAZMINĮ PJAUSTYMĄ GALITE SUSI-ŽALOTI ARBA SUŽALOTI KITUS. VIRINDAMI AR PJAUSTYDAMI LAIKYKITĖS ATSARGUMO PRIEMONIŲ. DARBDAVIO SAUGUMO PRAKTIKA TURI BŪTI PAGRĮSTA GAMINTOJO PATEIKTAIS DUOMENIMIS APIE PAVOJŲ.
------------------	---

ELEKTROS SMŪGIS – gali būti mirtinas.

- Sumontuokite ir įžeminkite virinimo ar plazminio pjaustymo įrenginį pagal atitinkamus standartus.
- Nelieskite veikiančių elektrinių dalių ar elektrodų plika oda, šlapiomis pirštinėmis ar šlapiais drabužiais.
- Izoliuokite save nuo įžeminimo ir apdirbamos detalės.
- Užtikrinkite, kad jūsų darbo padėtis yra saugi.

DŪMAI IR DUJOS – gali būti pavojingi sveikatai.

- Nelaikykite galvos dūmuose.
- Dūmams ir dujoms pašalinti iš kvėpavimo srities ir bendrosios srities naudokite ventiliaciją ir ištraukimą ties arka.

ARKINIAI SPINDULIAI – gali sužaloti akis ir nudeginti odą.

- Apsaugokite akis ir kūną. Naudokite tinkamą virinimo / plazminio pjaustymo ekraną ir filtravimo lęšį bei dėvėkite apsauginius drabužius.
- Pašalinius asmenis apsaugokite atitinkamais ekranais ar užuolaidomis.

GAISRO PAVOJUS



- Žiežirbos (purslai) gali sukelti gaisrą. Todėl turite patikrinti, ar šalia nėra degių medžiagų.

TRIUKŠMAS – itin didelis triukšmas gali pakenkti klausai

- Apsaugokite ausis. Naudokite ausines ar kitą klausos apsaugą.
- Pašalinius asmenis įspėkite apie pavojų.

BLOGAS FUNKCIONAVIMAS – blogai funkcionuojant skambinkite ekspertams.

PRIEŠ MONTUODAMI AR EKSPLOATUODAMI PERSKAITYKITE IR SUPRASKITE INSTRUKCIJŲ VADOVĄ. APSISAUGOKITE IR APSAUGOKITE KITUS!

ĮSPĖJIMAS	Nenaudokite maitinimo šaltinio užšalusiems vamzdžiams atšildyti.	
DĖMESIO	„Class A“ tipo įranga neskirta naudoti gyvenamosiose patalpose, kur elektros srovė tiekama viešaisiais žemosios įtampos elektros tinklais. Gali kilti sunkumų tokiose patalpose nustatant elektromagnetinį „class A“ įrangos suderinamumą dėl laidais sklindančių, taip pat ir spinduliuojamų trikdžių.	
DĖMESIO	Šis produktas yra skirtas išskirtinai pjovimui plazma. Bet kuris kitas panaudojimas gali sukelti asmeninius sužeidimus ir (arba) sugadinti įrengimą.	
DĖMESIO	Prieš montuodami ar eksploatuodami perskaitykite ir supraskite instrukcijų vadovą.	

1 NODAĻA : DROŠĪBAS

1.0 Piesardzības pasākumi

ESAB metināšanas un plazmas griešanas iekārtu lietotāji ir pilnībā atbildīgi par to, lai ikviens, kas darbojas iekārtas tuvumā vai ar to, ievērotu attiecīgus drošības priekšnoteikumus. Piesardzības pasākumiem ir jāatbilst prasībām, kādas attiecas uz šāda veida metināšanas vai griešanas iekārtu. Papildus standarta noteikumiem, kas attiecas uz darba vietu, būtu jāievēro tālāk minētie papildu ieteikumi.

Viss darbs jāveic apmācītam personālam, kas labi pārzina metināšanas vai plazmas griešanas iekārtu darbību. Nepareiza darbošanās ar iekārtu var novest pie bīstamām situācijām, ka rezultātā operators var tik ievainots un iekārta bojāta.

1. Ikvienam, kas izmanto metināšanas vai plazmas griešanas iekārtu, ir jāpārzina:
 - iekārtas darbība
 - avārijas slēdžu atrašanās vieta
 - iekārtas funkcijas
 - attiecīgi piesardzības pasākumi
 - metināšana un / vai plazmas loka griešana
2. Operatoram ir jāgādā, lai:
 - kad iekārta tiek iedarbināta, tās darbības zonā neatrastos neviena nepiederoša persona.
 - neviens nebūtu neaizsargāts, kad loks ir piešķilts.
3. Darba vietai ir jābūt:
 - piemērotai dotajam nolūkam;
 - tīrai.
4. Personiskais drošības aprīkojums:
 - vienmēr apģērbiet ieteicamo personiskās drošības aprīkojumu, piemēram aizsargbrilles, nedegošu apģērbu, drošības cimdus.
 - Neapvelciet vaļīgas lietas, piemēram šalles, rokassprādzes, gredzenus, utt., kas var iesprūst vai radīt apdegumus.
5. Vispārēji piesardzības pasākumi:
 - pārliecinieties, lai atgriešanās kabelis būtu cieši pievienots;
 - darbu ar augstsprieguma iekārtu **drīkst veikt tikai kvalificēts elektriķis**;
 - tuvumā jāatrodas skaidri apzīmētam attiecīgam ugunsdzēsīgam aparātam;
 - iekārtas eļļošanu un apkopi **nedrīkst** veikt tās darbības laikā.



Utilizējiet elektronisko aprīkojumu, nododot to otrreizējās pārstrādes punktā!

Ievērojot Eiropas Direktīvu 2002/96/EK par elektriskā un elektroniskā aprīkojuma atkritumiem un īstenojot to saskaņā ar valsts tiesību aktiem, elektriskās un/vai elektroniskās iekārtas, kam beidzies kalpošanas laiks, jānodod utilizācijai otrreizējās pārstrādes punktos. Kā par iekārtu atbildīgajai personai, jums ir pienākums iegūt informāciju par apstiprinātajām savākšanas vietām.

Lai iegūtu plašāku informāciju, sazinieties ar tuvāko ESAB izplatītāju.

ESAB var nodrošināt visus vajadzīgos piederumus aizsardzībai un metināšanai.

ESAB CUTMASTER 120

BRĪDINĀJUMS	METINĀŠANA UN PLAZMAS GRIEŠANA VAR BŪT BĪSTAMA JUMS UN CITIEM. IEVĒROJIET PIESARDZĪBAS PASĀKUMUS, KAD METINĀT VAI VEICAT GRIEŠANU. UZZINIET PAR JŪSU DARBA DEVĒJA DROŠĪBAS PRAKSI, KAM JĀBŪT BALSTĪTAI UZ RAŽOTĀJA BĪSTAMĪBAS DATIEM.
--------------------	--

ELEKTRISKĀS STRĀVAS TRIECIENS – var nogalināt.

- Uzstādiet un saņemiet metināšanas vai plazmas griešanas iekārtu saskaņā ar attiecīgajiem standartiem.
- Nepieskarieties darbībā esošām elektriskajām detaļām vai elektrodiem ar ādu, slapjiem cimdiem vai mitru apģērbu.
- Izolējieties no zemes un apstrādājamā materiāla.
- Pārliecinieties, ka jūsu darba stāvoklis ir drošs.

IZGAROJUMI UN GĀZES – var būt bīstamas veselībai.

- Turiet galvu tālāk no izgarojumiem.
- Izmantojiet ventilāciju, noņēmēju pie loka vai abus, lai izvadītu izgarojumus un gāzes no jūsu elpošanas zonas un apkārtnes.

LOKA STAROJUMS – var ievainot acis un apdedzināt ādu.

- Aizsargājiet acis un ķermeni. Izmantojiet pareizu metināšanas / plazmas griešanas aizsargekrānu un filtra lēcas, kā arī apģērbiet aizsargapģērbu.
- Aizsargājiet blakus stāvētājus ar attiecīgiem ekrāniem vai aizkariem.

AIZDEGŠANĀS DRAUDI

- Dzirksteles (šļaksti) var izraisīt aizdegšanos. Tādēļ pārliecinieties, lai tuvumā neatrastos viegli uzliesmojoši materiāli.

TROKSNIS – pārāk liels troksnis var sabojāt dzirdi.

- Aizsargājiet ausis. Izmantojiet ausu sildītāju vai citu dzirdes aizsardzības līdzekli.
- Brīdiniet blakus stāvētājus par iespējamo risku.

NEPAREIZA DARBĪBA – nepareizas darbības gadījumā meklējiet eksperta palīdzību.

PIRMS UZSTĀDĪŠANAS VAI DARBA VEIKŠANAS IZLASIET UN IZPROTIET INSTRUKCIJU ROKASGRĀMATU. AIZSARGĀJIET SEVI UN CITUS!

BRĪDINĀJUMS	Neizmantojiet barošanas avotu, lai atkausētu sasalušas caurules.
--------------------	--

UZMANĪBU	A klases iekārtas nav paredzētas lietošanai dzīvojamās mājās, kurās elektriskā strāva tiek piegādāta, izmantojot publisko zemsprieguma elektrotīklu. Šādās vietās var būt grūtības nodrošināt A klases iekārtu elektromagnētisko saderību, ņemot vērā pārvades un starojuma izraisītos traucējumus.	
-----------------	---	---

UZMANĪBU	Šis izstrādājums ir paredzēts tikai griešanai ar plazmu. Izmantojot to citādā veidā, var rasties traumas un/vai aprīkojuma bojājumi.
-----------------	--

UZMANĪBU	Pirms uzstādīšanas vai darba veikšanas izlasiet un izprotiet	
-----------------	--	---

HOOFDSTUK 1: VEILIGHEID

1.0 Veiligheidsvoorschriften

Gebruikers van ESAB-las- en plasmasnijapparaten moeten er voor zorgen dat iedereen die met, of in de buurt van, het apparaat werkt zich aan de betreffende veiligheidsvoorschriften houdt. De veiligheidsvoorschriften moeten aan de eisen voor dit type las- of plasmasnijapparaat voldoen. Houd u aan de volgende aanbevelingen en aan de tot standaardregels die voor de werkplek gelden.

Het werk moet worden uitgevoerd door getraind personeel dat goed bekend is met de bediening van las- of plasmisnijapparaten. Onjuiste bediening van de apparatuur kan leiden tot gevaarlijke situaties, die kunnen leiden tot persoonlijk letsel en schade aan het apparaat.

1. Iedereen die las- of plasmasnijapparaten gebruikt, moet bekend zijn met:
 - de bediening
 - de locatie van noodstop
 - de werking
 - de relevante veiligheidsvoorschriften
 - lassen en/of plasmasnijden
2. Degene die het apparaat bedient, moet ervoor zorgen dat:
 - er zich geen ongeautoriseerd personeel in het werkgebied van het apparaat bevindt wanneer dit wordt opgestart
 - niemand onbeschermd is wanneer de boog wordt gestart
3. Het werkgebied moet:
 - geschikt zijn voor het doel
 - vrij zijn van tocht
4. Middelen voor uw persoonlijke veiligheid:
 - Draag altijd de aanbevolen middelen voor persoonlijke veiligheid, zoals een veiligheidsbril, vlambestendige kleding en veiligheidshandschoenen.
 - Draag geen loszittende voorwerpen, zoals dassen, armbanden, ringen, enz. Deze kunnen verstrikt raken en brandwonden veroorzaken.
5. Algemene voorzorgsmaatregelen:
 - Zorg dat de retourkabel correct is aangesloten.
 - Werkzaamheden met apparatuur met een hoog voltage **mogen alleen door een gekwalificeerde elektrotechnicus worden uitgevoerd.**
 - De juiste brandblusapparatuur moet duidelijk zijn aangegeven en binnen handbereik staan.
 - Tijdens de bediening van het apparaat **mogen geen** smering en onderhoud worden uitgevoerd.



Breng afgedankte elektronische apparatuur naar een recyclestation!

In overeenstemming met de Europese richtlijn 2002/96/EG betreffende afgedankte elektrische en elektronische apparatuur en de toepassing hiervan overeenkomstig nationale regelgeving, moet elektrische en/of elektronische apparatuur aan het einde van de levensduur naar een recyclestation worden gebracht.

Als verantwoordelijke voor de apparatuur moet u zelf informatie inwinnen over goedgekeurde inzamelpunten.

Neem voor meer informatie contact op met de dichtstbijzijnde ESAB-dealer.

ESAB heeft alle benodigde lasbeschermingsvoorzieningen en accessoires voor u.

ESAB CUTMASTER 120

WAARSCHUWING	LASSEN EN PLASMASNIJDEN KUNEN PERSOONLIJK LETSEL EN LETSEL BIJ ANDEREN VEROORZAKEN. NEEM VOORZORGSMAATREGELEN WANNEER U LAST OF SNIJDT. VRAAG UW WERKGEVER WELKE MAATREGELEN U MOET TREFFEN, OP BASIS VAN DE RISICOGEGEVENS VAN DE FABRIKANT.
---------------------	--

ELEKTRISCHE SCHOK - kan dodelijk zijn.

- Installeer en aard de las- of plasmasnijunit volgens de geldende normen.
- Raak geen elektrische onderdelen of elektrodes die onder stroom staan met de blote huid, natte hand schoenen of natte kleding aan.
- Isoleer uzelf van de aarde en het werkstuk.
- Zorg voor een goede werkhouding.

ROOK EN GAS - kunnen gevaarlijk voor de gezondheid zijn.

- Houd uw hoofd uit de rook.
- Gebruik ventilatie of boogextractie, of beide, om rook en gassen uit de ademzone en de algemene ruimte te verwijderen.

BOOGSTRALEN - kunnen letsel aan ogen en huid veroorzaken.

- Bescherm uw lichaam en uw ogen. Gebruik het juiste las/plasmasnijscherm en filterlens, en draag bescher - mende kleding.
- Bescherm omstanders met geschikte schermen of gordijnen.

BRANDGEVAAR

- Vonken (spatten) kunnen brand veroorzaken. Zorg daarom dat er geen ontvlambare materialen in de buurt staan.

LAWAAI - te veel lawaai kan het gehoor beschadigen.

- Bescherm uw oren. Gebruik oorbeschermers of een andere gehoorbescherming.
- Wijs omstanders op het risico.

DEFECTEN - bel voor assistentie van een expert als het apparaat defect is.

LEES EN BEGRIJP DE INSTRUCTIEHANDELING VOORDAT U HET APPARAAT BEDIENT. BESCHERM UZELF EN ANDEREN!

WAARSCHUWING	Gebruik de stroombron niet voor het ontdooien van bevroren pijpen.
---------------------	---

LET OP	Class A-apparatuur is niet bedoeld voor gebruik in woonomgevingen waar de elektrische stroom wordt geleverd via het openbare elektriciteitsnet, dat een lage spanning heeft. In dergelijke omgevingen kunnen moeilijkheden ontstaan met de elektromagnetische compatibiliteit van Class A-apparatuur als gevolg van geleidings- en stralingsverstoringen.	
---------------	--	---

LET OP	Dit product is uitsluitend bedoeld voor plasmasnijden. Elk ander gebruik kan persoonlijk letsel en/of schade aan de apparatuur tot gevolg hebben.
---------------	--

LET OP	Lees en begrijp de instructiehandeling voordat u het apparaat bedient.	
---------------	---	---

KAPITTEL 1: SIKKERHETSINSTRUKSER

1.0 Sikkerhetsinstruksjer

Brukere av ESAB-utstyr for sveising og plasmaskjæring har det endelige ansvaret for å forsikre seg om at enhver som arbeider med eller er i nærheten av utstyret følger alle relevante sikkerhetsinstruksjer. Sikkerhetsinstruksene må oppfylle kravene som gjelder for denne typen utstyr for sveising eller plasmaskjæring. I tillegg til standardforskriftene som gjelder for arbeidsstedet, må det tas hensyn til de følgende anbefalingene.

Alt arbeid må utføres av opplært personell som har god kjennskap til bruken av utstyr for sveising og plasmaskjæring. Ukorrekt bruk av utstyret kan føre til farlige situasjoner som kan resultere i personskaade på operatøren og skade på utstyret.

1. Alle som bruker utstyr for sveising eller plasmaskjæring må kjenne til:
 - riktig bruk
 - hvor nødstopp finnes
 - hvordan utstyret fungerer
 - relevante sikkerhetsinstruksjer
 - sveising og/eller plasmaskjæring
2. Operatøren må forsikre seg om at:
 - ingen uvedkommende person befinner seg innenfor utstyrets arbeidsområde når det startes opp.
 - ingen er uten beskyttelse når buen tennes.
3. Arbeidsstedet må:
 - være egnet til formålet
 - være fritt for trekk
4. Personlig verneutstyr:
 - Bruk alltid personlig verneutstyr, slik som vernebriller, flammesikker bekledning og sveisehansker.
 - Ikke bruk noe som er løstsittende, slik som skjerf, armbånd, ringer osv., da disse kan sette seg fast eller forårsake brannskader.
5. Generelle forholdsregler:
 - Kontroller at returkabelen er godt tilkopleet.
 - Arbeid på høyspenningsutstyr **kan bare utføres av en kvalifisert elektriker**.
 - Egnet brannslukkingsutstyr må være tydelig merket og må finnes like i nærheten.
 - Smøring og vedlikehold **må ikke** utføres på utstyret mens det brukes.



Lever elektronisk utstyr inn til et mottak for gjenvinning!

I henhold til EU-direktivet 2012/19/EF om elektrisk og elektronisk avfall og direktivets implementering i samsvar med nasjonale lovregler, skal elektrisk og/eller elektronisk utstyr etter endt levetid leveres inn til et mottak for gjenvinning.

Som ansvarlig for utstyret er det ditt ansvar å skaffe til veie informasjon om godkjente innsamlingsstasjoner.

Kontakt nærmeste ESAB-forhandler for mer informasjon.

ESAB kan tilby alt nødvendig tilbehør og beskyttelsesutstyr for bruk ved sveising.

ESAB CUTMASTER 120

ADVARSEL

SVEISING OG PLASMASKJÆRING KAN FØRE TIL SKADE PÅ DEG SELV OG ANDRE. TA FORHOLDSREGLER VED SVEISING OG SKJÆRING. SPØR ETTER DIN ARBEIDSGIVERS SIKKERHETS-FORSKRIFTER SOM SKAL VÆRE BASERT PÅ PRODUSENTENS RISIKODATA.

ELEKTRISK STØT - Kan drepe.

- Enheten for sveising eller plasmaskjæring må installeres og tilkoples jordledning i henhold til gjeldende forskrifter.
- Ikke berør spenningsatte elektriske komponenter med bar hud, våte hansker eller våt bekledding.
- Isoler deg selv fra jord og fra arbeidsstykket.
- Forsikre deg om at du har en sikker arbeidsstilling.

SVEISERØYK OG GASSER - Kan gi helseskade.

- Hold hodet vekk fra sveiserøyk.
- Bruk ventilasjon, avsug ved lysbuen, eller begge deler, for å hindre at du puster inn røyk og gasser, og for å holde røyk og gasser borte fra området.

LYSBUESTRÅLER - Kan skade øynene og brenne huden.

- Beskytt øynene og kroppen. Bruk riktig type sveisemaske og beskyttelsesglass for sveising/plasmaskjæring og bruk vernebekledding.
- Bruk egnede avskjermingsmidler og gardiner for å beskytte personer i nærheten.

BRANNFARE

- Gnister (sveisesprut) kan forårsake brann. Sørg derfor for at det ikke finnes lettantennelige materialer i nærheten.

STØY - Kraftig støy kan gi hørselsskade.

- Beskytt ørene. Bruk hørselsvern.
- Advar personer i nærheten om risikoen.

FUNKSJONSSVIKT - Kontakt en ekspert for hjelp ved funksjonssvikt.

**LES OG FORSTÅ INSTRUKSJONSHÅNDBOKEN FØR INSTALLASJON OG BRUK.
BESKYTT DEG SELV OG ANDRE!**

ADVARSEL

Ikke bruk strømkilden til å tine frose rør.

FORSIKTIG

Klasse A-utstyr er ikke beregnet på bruk i boligområder der strømmen leveres av den offentlige lavspenningsstrømforsyningen. Det kan være vanskelig å sikre elektromagnetisk kompatibilitet for klasse A-utstyr i slike omgivelser på grunn av ledningsbårne forstyrrelser og strålingsforstyrrelser.



FORSIKTIG

Produktet er utelukkende beregnet på plasmaskjæring. Eventuell annen bruk kan medføre personskade og/eller skade på utstyr.

FORSIKTIG

Les og forstå instruksjonshåndboken før installasjon og bruk.

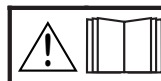

ROZDZIAŁ 1: ŚRODKI OSTROŻNOŚCI

1.0 Środki ostrożności

Użytkownicy sprzętu do spawania oraz cięcia firmy ESAB plazmowego posiadają obowiązek upewnienia się, że każdy, kto pracuje ze sprzętem lub w jego pobliżu zachowuje wszystkie stosowne środki ostrożności. Środki ostrożności muszą spełniać wymagania dotyczące tego typu sprzętu do spawania i cięcia plazmowego. Oprócz standardowych regulacji dotyczących miejsca pracy należy przestrzegać poniższych zaleceń.

Całość prac musi być wykonywana przez wykwalifikowany personel dobrze zaznajomiony z działaniem sprzętu do spawania i cięcia plazmowego. Niewłaściwa obsługa sprzętu może doprowadzić do niebezpiecznych sytuacji, które mogą skutkować zranieniem operatora oraz uszkodzeniem sprzętu.

1. Każda osoba używająca sprzętu do spawania lub cięcia plazmowego musi być obeznana z:
 - jego obsługą,
 - umiejscowieniem wyłączników bezpieczeństwa,
 - jego zasadą działania,
 - odpowiednimi środkami ostrożności,
 - spawaniem i/lub cięciem plazmowym.
2. Operator musi upewnić się, że:
 - w miejscu, gdzie znajduje się sprzęt, w chwili jego uruchamiania, nie przybywa żadna nieuprawniona osoba,
 - każdy posiada odpowiednią ochronę w momencie zapalania łuku.
3. Miejsce pracy musi:
 - być przeznaczone do danego celu,
 - być wolne od przeciągów.
4. Środki ochrony indywidualnej:
 - należy zawsze nosić zalecane środki ochrony indywidualnej, takie jak okulary ochronne, ognioodporna odzież, rękawice ochronne,
 - nie nosić luźnych części ubioru, takich jak szaliki, bransoletki, pierścienie itp., które mogą zostać uwięzione lub spowodować poparzenia.
5. Ogólne środki ostrożności:
 - należy upewnić się, że przewód powrotny jest bezpiecznie podłączony.
 - praca ze sprzętem pod wysokim napięciem **może być wykonywana wyłącznie przez wykwalifikowanego elektryka**,
 - w pobliżu miejsca pracy musi znajdować się odpowiedni, wyraźnie oznaczony sprzęt przeciwpożarowy,
 - **nie** smarować ani nie przeprowadzać konserwacji sprzętu w trakcie jego pracy.



Zużyty sprzęt elektroniczny należy przekazać do zakładu utylizacji odpadów!

Zgodnie z dyrektywą europejską 2002/96/WE w sprawie zużytego sprzętu elektrycznego i elektronicznego (WEEE) oraz jej zastosowaniem w świetle prawa krajowego, wyeksploatowane urządzenia elektryczne i/lub elektroniczne należy przekazywać do zakładu utylizacji odpadów.

Jako osoba odpowiedzialna za sprzęt, masz obowiązek uzyskać informacje o odpowiednich punktach zbiórki odpadów.

Dodatkowych informacji udzieli lokalny dealer firmy ESAB.

Firma ESAB może dostarczyć wszystkie niezbędne zabezpieczenia i akcesoria do cięcia.

ESAB CUTMASTER 120

OSTRZEŻENIE	SPAWANIE ORAZ CIĘCIE PLAZMOWE MOŻE SPOWODOWAĆ OBRAŻENIA ZARÓWNO OPERATORA JAK I OSÓB POSTRONNYCH. W TRAKCIE SPAWANIA LUB CIĘCIA, PLAZMOWEGO NALEŻY PRZEDSIĘWZIĄĆ WSZELKIE ŚRODKI OSTROŻNOŚCI. NALEŻY ZAPYTAĆ O PRAKTYKI BEZPIECZEŃSTWA PRACODAWCY, KTÓRE POWINNY BYĆ OPARTE NA DANYCH DOTYCZĄCYCH RYZYKA PODANYCH PRZEZ PRODUCENTA.
--------------------	--

PORAŻENIE PRĄDEM ELEKTRYCZNYM – grozi śmiercią.

- Należy zamontować oraz uziemić jednostkę do spawania lub cięcia plazmowego zgodnie z odpowiednimi standardami.
- Nie dotykać części elektrycznych ani elektrod odsłoniętą skórą, wilgotnymi rękawicami lub wilgotnym ubraniem.
- Należy odizolować się od ziemi oraz od ciętego lub spawanego przedmiotu.
- Należy upewnić się, że stanowisko pracy jest bezpieczne.

OPARY ORAZ GAZY – mogą stanowić zagrożenie dla zdrowia.

- Należy trzymać głowę jak najdalej od oparów.
- Należy użyć systemu wentylacji, systemu odprowadzania wyziewów na łuku lub obydwu tych systemów w celu odprowadzania oparów oraz gazów daleko od obszaru oddychania oraz obszaru pracy.

PROMIENIOWANIE WYTWARZANE PODCZAS SPAWANIA – może uszkodzić oczy oraz poparzyć skórę.

- Należy chronić oczy oraz całe ciało. Należy stosować właściwe ekrany do spawania / cięcia plazmowego oraz odpowiednie filtry spawalnicze, a także nosić odzież ochronną.
- Należy chronić osoby postronne poprzez stosowanie odpowiednich ekranów lub zasłon.

NIEBEZPIECZEŃSTWO POŻARU

- Iskry (rozpryski) mogą spowodować pożar. Z tego powodu należy się upewnić, że w pobliżu nie ma żadnych łatwopalnych materiałów.

HAŁAS – nadmierny hałas może uszkodzić słuch.

- Należy chronić uszy. Stosować osłony na uszy lub inną ochronę słuchu.
- Należy ostrzec osoby postronne o grożącym im ryzyku.

WADLIWE DZIAŁANIE – w przypadku wadliwego działania należy zadzwonić do eksperta po pomoc.

NALEŻY PRZECZYTAĆ ZE ZROZUMIENIEM NINIEJSZĄ INSTRUKCJĘ OBSŁUGI PRZEDPRZYSTĄPIENIEM DO MONTAŻU LUB OBSŁUGI SPRZĘTU. CHROŃ SIEBIE I INNYCH!

OSTRZEŻENIE	Nie wolno używać źródła prądu do rozmrażania zamrożonych rur i innych celów niż prace spawalnicze.
--------------------	---

PRZESTROGA	Urządzenia Class A nie są przeznaczone do użytku w budynkach, gdzie zasilanie elektryczne pochodzi z publicznego niskonapięciowego układu zasilania. Ze względu na przewodzone i emitowane zakłócenia, w takich lokalizacjach mogą występować potencjalne trudności w zapewnieniu kompatybilności elektromagnetycznej urządzeń Class A.	
-------------------	--	---

PRZESTROGA	Ten produkt jest przeznaczony wyłącznie do cięcia łukiem plazmowym. Jakikolwiek inne zastosowanie może spowodować obrażenia ciała i/lub uszkodzenia urządzenia.
-------------------	--

PRZESTROGA	Należy przeczytać ze zrozumieniem niniejszą instrukcję obsługi przed przystąpieniem do montażu lub obsługi sprzętu.	
-------------------	--	---

SEÇÃO 1: MEDIDAS DE SEGURANÇA

1.0 Medidas de Segurança

Todos aqueles que utilizam equipamentos de solda e corte da ESAB devem certificar-se de que todas as pessoas que trabalhem ou estiverem perto da máquina de solda ou corte tenham conhecimento das medidas de segurança. Estas medidas de segurança devem estar de acordo com os requerimentos que se aplicam às máquinas de solda e corte. Leia atentamente as recomendações a seguir. As recomendações em relação ao seu local de trabalho relativas à segurança também devem ser seguidas.

Uma pessoa com experiência em equipamentos de solda e corte deve ser responsável pelo trabalho. A operação incorreta da máquina pode danificar o equipamento e causar riscos à sua saúde.

1. Todos aqueles que utilizarem os equipamentos de solda e corte devem estar familiarizados com:
 - sua operação.
 - localização das chaves de emergência.
 - sua função.
 - medidas de segurança relevantes.
 - processo de solda e/ou corte
2. O operador deve certificar-se de que:
 - somente pessoas autorizadas mexam no equipamento.
 - todos estejam protegidos quando o equipamento for utilizado.
3. A área de trabalho deve ser:
 - apropriada para esta aplicação.
 - sem ventilação excessiva.
4. Equipamentos de segurança pessoal:
 - sempre use equipamentos de segurança como óculos de proteção, luvas e roupas especiais.
 - não utilize acessórios que não sejam adequados à operação de solda ou corte, como colar, pulseira, etc.
5. Precauções gerais:
 - certifique-se de que o cabo de trabalho esteja firmemente conectado.
 - o trabalho em equipamentos de alta voltagem **deve ser feito por pessoas qualificadas**.
 - tenha um extintor perto da área onde a máquina estiver situada.
 - **não** faça a manutenção ou lubrificação do equipamento durante a operação de corte.



Eliminação de equipamento electrónico nas instalações de reciclagem!

De acordo com a Directiva Europeia 2002/96/CE relativa a resíduos de equipamentos eléctricos e electrónicos e respectiva implementação em conformidade com o direito nacional, o equipamento eléctrico e/ou electrónico que atingiu o fim da sua vida útil deve ser eliminado em instalações de reciclagem.

Como responsável pelo equipamento, faz parte das suas funções informar-se sobre estações de recolha aprovadas.

Para mais informações, contacte o revendedor mais perto de si.

A ESAB pode fornecer-lhe toda a protecção e acessórios de soldadura necessários.

ESAB CUTMASTER 120

AVISO

O PROCESSO DE SOLDA E CORTE PODE CAUSAR DANOS À SUA SAÚDE E A DE OUTROS. TOME AS MEDIDAS DE SEGURANÇA APROPRIADAS AO SOLDAR OU CORTAR. PEÇA AO SEU EMPREGADOR PARA TER ACESSO ÀS NORMAS DE SEGURANÇA.

CHOQUE ELÉTRICO - pode ser fatal!

- instale e aterre o equipamento de solda ou corte de acordo com a norma de segurança local.
- não toque as partes elétricas ou o eletrodo, sem a proteção adequada, com luvas molhadas ou com pano molhado.
- não encoste no aterramento nem na peça de trabalho.
- certifique-se de que a área de trabalho é segura.

FUMAÇA E GASES - podem ser nocivos à saúde.

- mantenha a cabeça longe da fumaça.
- utilize ventilação e/ou extração de fumaça na zona de trabalho.

RAIOS DO ARCO - podem causar queimaduras e danificar a sua visão.

- proteja os olhos e o corpo. Use a lente de solda/corte correta e roupas apropriadas.
- proteja as outras pessoas com cortinas apropriadas.

FOGO

- agulhas podem causar fogo. Certifique-se de que não há nenhum produto inflamável não esteja na área de trabalho.

RUÍDO - ruído em excesso pode prejudicar a sua audição.

- proteja o seu ouvido. Use protetor auricular.
- informe as pessoas na área de trabalho dos riscos de ruído em excesso e da necessidade de se usar protetor auricular.

MAU FUNCIONAMENTO - caso a máquina não opere como esperado, chame uma pessoa especializada.

LEIA E COMPREENDA O MANUAL DE INSTRUÇÕES ANTES DE INSTALAR OU OPERAR A MÁQUINA. PROTEJA OS OUTROS E A SI MESMO!

AVISO

Não utilizar a fonte de soldagem para descongelar tubos congelados.

ATENÇÃO

O equipamento de Class A não se destina a ser utilizado em zonas residenciais onde a alimentação eléctrica seja fornecida pela rede pública de baixa tensão. Poderá haver dificuldades em garantir a compatibilidade electromagnética de equipamento de Class- A nessas zonas devido a perturbações conduzidas bem como a perturbações radiadas.

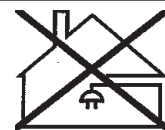

ATENÇÃO

Este produto destina-se exclusivamente a corte a plasma. Qualquer outra utilização poderá resultar em ferimentos pessoais e/ou danos no equipamento.

ATENÇÃO

Leia e compreenda o manual de instruções antes de instalar ou operar a máquina.



CAPITOL 1: MĂSURI DE SIGURANȚĂ

1.0 Măsuri de siguranță

Utilizatorii echipamentelor ESAB pentru sudare și tăiere cu plasmă au responsabilitatea extrem de importantă de a se asigura că toate persoanele care lucrează la sau lângă acest echipament respectă toate măsurile de siguranță relevante. Măsurile de siguranță trebuie să respecte toate cerințele aplicabile acestui tip de echipament de sudare sau tăiere cu plasmă. Următoarele recomandări trebuie respectate în plus față de reglementările standard aplicabile locului de muncă.

Toate lucrările trebuie efectuate de către personalul calificat, familiarizat cu funcționarea echipamentului de sudare sau tăiere cu plasmă. Utilizarea incorectă a echipamentului poate duce la situații periculoase care pot avea ca rezultat vătămarea operatorului sau avarierea echipamentului.

1. Orice utilizator al echipamentului de sudare sau tăiere cu plasmă trebuie să fie familiarizat cu:
 - funcționarea lui
 - localizarea opririlor de urgență
 - funcționarea sa
 - măsurile de siguranță relevante
 - sudarea și/sau tăierea cu plasmă
2. Operatorul trebuie să se asigure că:
 - nicio persoană nu staționează în zona în care se lucrează cu echipamentul în momentul pornirii acestuia.
 - nu există persoane neprotejate în momentul aprinderii arcului.
3. Locul de muncă trebuie să:
 - fie adecvat activității desfășurate
 - nu aibă curenți de aer
4. Echipament de protecție individuală:
 - Purtați întotdeauna echipamentul de protecție individuală recomandat, cum ar fi ochelarii de protecție, îmbrăcăminte ignifugă, mănuși de protecție.
 - Nu purtați articole cum ar fi eșarfe/fulare, brățări, inele, etc. care se pot desprinde ușor și care se pot prinde și pot cauza arsuri.
5. Măsuri generale de precauție:
 - Asigurați-vă de racordarea corectă a cablului de retur.
 - Lucrul cu echipament sub tensiune înaltă poate fi efectuat doar de către un electrician calificat.
 - Echipamentul de stingere a incendiilor trebuie indicat cu claritate și trebuie să fie la îndemână.
 - Lubrifierea și întreținerea nu trebuie efectuate în timpul funcționării.



Predați echipamentul electronic uzat la centrul de reciclare!

În conformitate cu prevederile Directivei Europene 2002/96/EC privind deșeurile de echipamente electrice și electronice, precum și cu implementarea acesteia conform legislației naționale, echipamentul electric și/sau electronic care a atins limita maximă a duratei de viață trebuie să fie predat la un centru de reciclare.

Ca persoană responsabilă pentru echipament, aveți responsabilitatea de a obține informațiile despre stațiile de colectare autorizate.

Pentru mai multe informații, contactați cel mai apropiat distribuitor ESAB.

ESAB vă poate furniza toate elementele de protecție și accesoriile pentru tăiere.

ESAB CUTMASTER 120

AVERTISMENT	SUDAREA ȘI TĂIEREA CU PLASMĂ POT FI VĂTĂMĂTOARE PENTRU DUMNEAVOASTRĂ ȘI PENTRU ALTE PERSOANE. LUAȚI MĂSURI DE PRECAUȚIE CÂND SU-DAȚI SAU TĂIAȚI. ÎNTREBAȚI ANGAJATORUL DESPRE PROCEDURILE DE LUCRU ÎN SIGURANȚĂ, PROCEDURI CARE TREBUIE SĂ SE BAZEZE PE DATELE PRODUCĂTORULUI PRIVIND PERICOLELE POSIBILE.
--------------------	---

ELECTROCUTAREA - Poate ucide.

- Montați și realizați împământarea unității de sudare sau tăiere cu plasmă, în concordanță cu standardele aplicabile.
- Nu atingeți cu mâna neprotejată, mănuși sau haine ude componentele electrice în funcțiune sau electrozii.
- Izolați-vă la pământ și la piesa de prelucrat.
- Asigurați-vă că aveți poziția corectă de lucru.

FUMUL ȘI GAZELE - pot fi periculoase pentru sănătate.

- Feriți-vă capul de fum.
- Folosiți ventilarea sau extragerea la arc, sau ambele, pentru a evacua fumul și gazele din zona dumneavoastră de respirație și din întregul perimetru.

RAZELE ARCULUI ELECTRIC - pot cauza rănirea ochilor și pot arde pielea.

- Protejați-vă ochii și corpul. Folosiți ecranele și lentilele de filtrare corespunzătoare sudării/tăierii cu plasmă și purtați îmbrăcăminte de protecție.
- Protejați-i pe cei din jurul dumneavoastră cu ecrane sau cortine adecvate.

RISC DE INCENDIU

- Scânteele (stropii) pot provoca incendii. Asigurați-vă, prin urmare, că nu există materiale inflamabile prin preajmă.

ZGOMOT - Zgomotul excesiv vă poate vătăma auzul.

- Protejați-vă urechile. Folosiți manșoane pentru urechi sau alte protecții auditive.
- Avertizați-i pe cei din jurul dumneavoastră asupra riscurilor.

DEFECȚIUNE - Cereți ajutorul unui expert în cazul unei defecțiuni.

**ÎNAINTE DE INSTALARE ȘI UTILIZARE, CITIȚI ȘI ÎNȚELEGEȚI MANUAL DE UTILIZARE .
PROTEJAȚI-VĂ PE DUMNEAVOASTRĂ ȘI PE CEILALȚI!**

AVERTISMENT	Nu utilizați sursa de alimentare pentru dezghețarea țevilor înghețate.
--------------------	---

AVERTISMENT	Echipamentele din Clasa A nu sunt destinate pentru utilizare în amplasamentele rezidențiale unde energia electrică este furnizată de sistemul public de alimentare de joasă tensiune. Datorită perturbațiilor de conductivitate și de radiație, pot exista dificultăți în asigurarea compatibilității electromagnetice a echipamentelor de clasă A în aceste locații.	
--------------------	--	---

AVERTISMENT	Acest produs este destinat exclusiv tăierii de plasmă. Orice alt scop de utilizare poate rezulta în răniri personale și/sau deteriorarea echipamentului.
--------------------	---

AVERTISMENT	Înainte de instalare și utilizare, citiți și înțelegeți manual de utilizare .	
--------------------	--	---

РАЗДЕЛ 1. ТЕХНИКА БЕЗОПАСНОСТИ

1.0 Техника безопасности

Пользователи сварочного оборудования ESAB отвечают за выполнение правил техники безопасности лицами, работающими на оборудовании и рядом с ним. Правила техники безопасности должны отвечать требованиям к безопасной эксплуатации сварочного оборудования этого типа. Помимо стандартных правил техники безопасности и охраны труда на рабочем месте рекомендуется следующее.

Все работы должны выполняться подготовленными лицами, знакомыми с эксплуатацией сварочного оборудования. Неправильная эксплуатация оборудования может вызвать опасные ситуации, приводящие к травмам персонала и повреждению оборудования.

1. Все лица, использующие сварочное оборудование, должны знать:
 - правила эксплуатации;
 - расположение органов аварийного останова;
 - функции оборудования;
 - правила техники безопасности;
 - технологию сварки и/или плазменной резки.
2. Оператор должен обеспечить:
 - удаление посторонних лиц из рабочей зоны оборудования при его запуске;
 - защиту всех лиц от воздействия сварочной дуги.
3. Рабочее место должно:
 - отвечать условиям эксплуатации;
 - не иметь сквозняков.
4. Средства защиты персонала:
 - Во всех случаях рекомендуется использовать индивидуальные средства защиты, например, защитные очки, огнестойкую спецодежду и защитные рукавицы.
 - При сварке запрещается носить свободную одежду и украшения, например, шарфы, браслеты, кольца, которые могут попасть в сварочное оборудование или вызвать ожоги.
5. Общие меры предосторожности:
 - Проверьте надежность подключения обратного кабеля.
 - Работы на оборудовании с высоким **должны производиться только квалифицированным электриком.**
 - В рабочей зоне должны находиться средства пожаротушения, имеющие ясную маркировку.
 - **Запрещается** проводить смазку и техническое обслуживание оборудования во время эксплуатации.



Отправляйте подлежащее утилизации электронное оборудование на предприятия по переработке отходов!

В соблюдение Европейской Директивы 2002/96/ЕС по утилизации электрического и электронного оборудования, и при ее осуществлении в соответствии с национальными законодательными актами, электрическое и/или электронное оборудование, которое достигло предельного срока эксплуатации, должно отправляться на предприятия по переработке отходов.

В качестве ответственного лица за оборудование вы отвечаете за получение информации по утвержденным станциям сбора отходов.

Для получения подробной информации обращайтесь к ближайшему дилеру компании ESAB.

Компания ESAB готова предоставить вам все средства защиты и принадлежности, необходимые для выполнения резки.

ESAB CUTMASTER 120

ПРЕДУПРЕЖДЕНИЕ	СВАРКА ПЛАЗМЕННАЯ И РЕЗКА ОПАСНЫ КАК ДЛЯ ИСПОЛНИТЕЛЯ РАБОТ, ТАК И ДЛЯ ПОСТОРОННИХ ЛИЦ. СОБЛЮДАЙТЕ ПРАВИЛА БЕЗОПАСНОСТИ. ОЗНАКОМЬТЕСЬ С ПРАВИЛАМИ ТЕХНИКИ БЕЗОПАСНОСТИ, ПРИНЯТЫМИ ВАШИМ РАБОТОДАТЕЛЕМ. ЭТИ ПРАВИЛА ДОЛЖНЫ УЧИТЫВАТЬ ДАННЫЕ О РИСКЕ, СОБРАННЫЕ ИЗГОТОВИТЕЛЕМ ОБОРУДОВАНИЯ.
-----------------------	---

ЭЛЕКТРИЧЕСТВО опасно для жизни.

- Сварочный агрегат должен устанавливаться и заземляться в соответствии с действующими нормами и правилами.
- Не допускайте контакта находящихся под напряжением деталей и электродов с незащищенными частями тела, мокрыми рукавицами и мокрой одеждой.
- Обеспечьте электрическую изоляцию оператора от земли и свариваемых деталей.
- Обеспечьте соблюдение безопасных рабочих расстояний.

ДЫМ И ГАЗЫ опасны для человека.

- Избегайте вдыхания дыма и газов.
- Во избежание отравления дымом или газами во время сварки обеспечьте общую вентиляцию помещения, а также вытяжную вентиляцию зоны сварки.

ИЗЛУЧЕНИЕ ДУГИ может вызвать поражение глаз и ожоги кожи.

- Защитите глаза и кожу. Для этого используйте защитные щитки, цветные линзы и защитную спецодежду.
- Для защиты посторонних лиц применяются защитные экраны или занавеси.

ПОЖАРНАЯ ОПАСНОСТЬ

- Искры (брызги металла) могут вызвать пожар. Убедитесь в отсутствии горючих материалов поблизости от места сварки.

ШУМ может привести к повреждению органов слуха

- Примите меры для защиты слуха. Используйте беруши или другие средства защиты слуха.
- Предупредите посторонних лиц об опасности.

НЕИСПРАВНОСТИ - При обнаружении неисправностей обратитесь к специалисту по сварочному оборудованию.

ПЕРЕД НАЧАЛОМ МОНТАЖА И ЭКСПЛУАТАЦИИ ВНИМАТЕЛЬНО ИЗУЧИТЕ ИНСТРУКЦИИ. ЗАЩИТИТЕ СЕБЯ И ДРУГИХ!

ПРЕДУПРЕЖДЕНИЕ	Запрещается использовать источник питания для оттаивания труб.
-----------------------	---

ПРЕДОСТЕРЕЖЕНИЕ	Оборудование Class A не предназначено для использования в жилых помещениях, где электроснабжение осуществляется из бытовых сетей низкого напряжения. В таких местах могут появиться потенциальные трудности обеспечения электромагнитной совместимости оборудования Class A вследствие кондуктивных и радиационных помех.	
------------------------	---	---

ПРЕДОСТЕРЕЖЕНИЕ	Данное оборудование предназначено исключительно для плазменной резки. Любое иное применение может привести к травме персонала и (или) повреждению оборудования .
------------------------	---

ПРЕДОСТЕРЕЖЕНИЕ	ПЕРЕД НАЧАЛОМ МОНТАЖА И ЭКСПЛУАТАЦИИ ВНИМАТЕЛЬНО ИЗУЧИТЕ ИНСТРУКЦИИ.	
------------------------	---	---

ČASŤ 1: BEZPEČNOSTNÉ OPATRENIA

1.0 Bezpečnostné opatrenia

Používatelia zariadenia na zváranie a plazmové rezanie od firmy ESAB nesú primárnu zodpovednosť za zabezpečenie toho, aby každý, kto pracuje na zariadení alebo v jeho blízkosti, dodržiaval všetky príslušné bezpečnostné opatrenia. Bezpečnostné opatrenia musia spĺňať požiadavky, ktoré platia pre tento typ zariadenia na zváranie alebo plazmové rezanie. Okrem štandardných predpisov, ktoré platia na pracovisku, by ste mali dodržiavať nasledovné odporúčania.

Všetky práce musí vykonávať školený personál dobre oboznámený s obsluhou zariadenia na zváranie alebo plazmové rezanie. Nesprávna obsluha zariadenia môže viesť k nebezpečným situáciám, ktoré môžu spôsobiť zranenie obsluhu a poškodenie zariadenia.

1. Každý, kto používa zariadenie na zváranie alebo plazmové rezanie, musí poznať:
 - jeho obsluhu,
 - polohu núdzových vypínačov,
 - jeho fungovanie,
 - príslušné bezpečnostné opatrenia,
 - zváranie a/alebo plazmové rezanie.
2. Obsluha musí zabezpečiť, aby:
 - v pracovnom priestore zariadenia nestála žiadna neoprávnená osoba, keď je v činnosti.
 - nikto nebol bez ochrany, keď sa vytvára oblúk.
3. Pracovisko musí:
 - byť vhodné na tento účel,
 - byť bez prievanu.
4. Osobné ochranné prostriedky:
 - Vždy noste odporúčané osobné ochranné prostriedky, ako sú bezpečnostné okuliare, ohňovzdorné oblečenie, bezpečnostné rukavice.
 - Nenoste voľne visiace časti odevu, ako sú šály, náramky, prstene, atď., ktoré by sa mohli zachytiť alebo spôsobiť popáleniny.
5. Všeobecné preventívne opatrenia:
 - Uistite sa, či je spätný kábel bezpečne pripojený.
 - Prácu na vysokonapäťovom zariadení **smie vykonávať len kvalifikovaný elektrikár**.
 - Vhodné hasiace zariadenia musia byť zreteľne označené a po ruke.
 - Mazanie a údržbu zariadenia nesmiete vykonávať počas jeho prevádzky.



Elektronické zariadenia likvidujte prostredníctvom recyklačných stredísk!

V súlade s európskou smernicou 2002/96/ES o odpade z elektrických a elektronických zariadení a v súlade s jej vykonávacími predpismi podľa vnútroštátneho zákonodarstva musí byť elektrické alebo elektronické zariadenie po skončení životnosti zlikvidované prostredníctvom recyklačných stredísk.

Ako osoba zodpovedná za zariadenie ste zodpovedný za získanie informácií o schválených zberniach tohto odpadu.

Bližšie informácie vám na požiadanie poskytne najbližší predajca ESAB.

Spoločnosť ESAB je schopná dodať všetky potrebné ochranné prostriedky na rezanie a príslušenstvo.

ESAB CUTMASTER 120

VAROVANIE	PRI ZVÁRANÍ A PLAZMOVOM REZANÍ MOŽETE ZRANIŤ SEBA ALEBO INÝCH. PRI ZVÁRANÍ ALEBO REZANÍ VYKONAJTE PREVENTÍVNE OPATRENIA. OPÝTAJTE SA SVOJHO ZAMESTNÁVATEĽA NA BEZPEČNÉ POSTUPY, KTORÉ BY SA MALI ZAKLADAŤ NA ÚDAJOCH VÝROBCU O NEBEZPEČENSTVÁCH.
------------------	---

ZÁSAH ELEKTRICKÝM PRÚDOM - Môže vás usmrtiť.

- Nainštalujte a uzemnite zvariaciu alebo plazmovú rezaciu jednotku v súlade s platnými normami.
- Nedotýkajte sa odhalenou časťou tela, mokrými rukavicami alebo mokrým odevom elektrických súčiastok alebo elektród pod prúdom.
- Izolujte sa od zeme a obrobku.
- Uistite sa, či je váš pracovný postoj bezpečný.

VÝPARY A PLYNY - Môžu ohrozovať zdravie.

- Nepribližujte hlavu k výparom.
- Používajte vetranie, odsávanie pri oblúku alebo oboje, aby ste odvedli výpary a plyny mimo oblasti dýchania a okolitého priestoru.

ŽIARENIE OBLÚKA - Môže spôsobiť poškodenie zraku a popálenie pokožky.

- Chráňte svoj zrak a telo. Používajte správny ochranný štít a filtračné sklo na zváranie a plazmové rezanie a noste ochranný odev.
- Chráňte okolostojacich vhodnými štítmí alebo clonami.

NEBEZPEČENSTVO POŽIARU

- Iskry (rozstrek) môžu spôsobiť požiar. Preto sa uistite, či v blízkosti nie sú žiadne horľavé materiály.

HLUK - Nadmerný hluk môže poškodiť sluch.

- Chráňte svoj sluch. Používajte klapky na uši alebo inú ochranu sluchu.
- Varujte okolostojacich pred rizikom.

PORUCHA - V prípade poruchy privolajte odborníka.

PRED INŠTALÁCIOU ALEBO OBSLUHOU SI PREČÍTAJTE NÁVOD NA OBSLUHU A UISTITE SA, ŽE STE MU POROZUMELI. CHRÁŇTE SEBA A INÝCH!

VAROVANIE	Nepoužívajte napájací zdroj na rozmrazovanie zamrznutých potrubí.
------------------	---

UPOZORNENIE	Zariadenie Class A nie je určené na použitie na obytných územiach, kde sa elektrická energia dodáva verejnou nízkonapäťovou rozvodnou sieťou. V týchto miestach sú možné potenciálne problémy so zabezpečením elektromagnetickej kompatibility zariadení Class A, s ohľadom na rušenie šírené po vodičoch i vyžarované rušenie.	
--------------------	---	---

UPOZORNENIE	Tento produkt je výlučne určený na plazmové rezanie. Akékoľvek iné používanie môže spôsobiť zranenie osôb a/alebo poškodenie zariadenia.
--------------------	--

UPOZORNENIE	Pred inštaláciou alebo obsluhou si prečítajte návod na obsluhu a uistite sa, že ste mu porozumeli.	
--------------------	--	---

POGLAVJE 1 - VARNOSTNI UKREPI

1.0 VARNOSTNI UKREPI

Uporabniki ESAB opreme za varjenje in rezanje s plazmo so dogovorni, da so vse, ki delajo z opremo ali se nahajajo v njeni bližini, seznanjeni z vsemi varnostnimi ukrepi. Varnostni ukrepi morajo ustrezati zahtevam tega tipa opreme za varjenje ali rezanje s plazmo. Upoštevajte naslednje nasvete zaradi standardnih odlokov, ki se nanašajo na delovno mesto.

Delo naj opravlja le izurjeno osebje, ki je popolnoma seznanjeno z delovanjem opreme za varjenje ali plazemsko rezanje. Nepravilna uporaba opreme lahko povzroči nevarnosti, ki lahko pripeljejo do poškodb delavca ali opreme za rezanje.

1. Vsi ki uporabljajo opremo za varjenje ali plazemsko rezanje naj bodo seznanjeni z:
 - načinom delovanja
 - položajem zasilnega izklopa
 - namenu
 - predpisanimi varnostnimi ukrepi
 - varjenjem in/ali plazemskim rezanjem
2. Delavec mora biti zagotoviti, da:
 - ko je oprema zagnana ni na delovnem mestu nobene nepooblaščen osebe.
 - da so vsi zaščiteni, ko se plazemski lok prižge.
3. Delovno mesto mora biti:
 - ustrezno za opravljanje dela
 - zaščiteno od prepiha
4. Osebna zaščitna oprema:
 - Obvezno uporabljajte predpisano osebno zaščitno opremo kot so zaščitna očala, zaščitna obleka, zaščitne rokavice.
 - Odstranite vse viseče stvari kot so nakit, naroknice, prstani ker jih lahko ujame oprema ali lahko povzročijo opekline.
5. Glavni ukrepi:
 - Prepričajte se, da je povratni kabel čvrsto pritrjen.
 - Delo z opremo pod visoko napetostjo lahko opravlja samo kvalificiran elektrik.
 - Predpisana gasilna oprema naj bo pri roki in dobro označena.
 - **Ne nanašajte mazila in ne vzdržujte opreme, ko je zagnana.**



Elektronsko opremo zavržite v ustanovi za recikliranje!

Evropska Direktiva 2002/96/ES o odpadni električni in elektronski opremi ter njeni uvedbi v nacionalno zakonodajo predpisuje ob koncu življenjske dobe obvezno predelavo električne in/ali elektronske opreme v ustanovi za recikliranje.

Kot odgovorna oseba za opremo ste odgovorni, da pridobite informacije o odobrenih zbiralnih mestih.

Za več informacij se obrnite na najbližjega prodajalca ESAB.

ESAB vam zagotavlja vsa potrebna zaščitna sredstva in pribor za rezanje.

ESAB CUTMASTER 120

OPOZORILO	VARJENJE IN PLAZEMSKO REZANJE LAHKO POVZROČITA POŠKODBE UPORABNIKA IN DRUGIH. BODITE POZORNI, KO VARI-TE ALI REŽETE. POIŠČITE NASVETE ZA VARNOST DELAVCEV, KI TEMELJIJO NA PODATKIH PROIZVAJALCA O NEVARNOSTI.
------------------	---

ELEKTRIČNI UDAR - Lahko ubije.

- Po predpisanih standardih namestite in ozemljite enoto za varjenje ali rezanje.
- Ne dotikajte se električnih delov z golo kožo, z mokrimi rokavicami ali z moko obleko.
- Izolirajte se od ozemljitve in od dela na katerem boste delali.
- Prepričajte se za varno oddaljenost od dela.

DIMI IN PLINI - So lahko nevarni za zdravje.

- Držite glavo stran od dimov.
- Uporablajte ventilacijo, ekstrakcijo pri loku, ali oboje, da spravite dime in pline stran od zone dihanja in delovnega mesta.

ŽARKI LOKA - Lahko poškodujejo oči in opečejo kožo.

- Zaščitite oči in telo. Uporabite predpisano masko za varjenje in plazemsko rezanje z zaščitnimi lečami in zaščitno obleko.
- Opozorite osebe v bližini na nevarnost.

NEVARNOST OGNJA

- Iskre lahko povzročijo požar. Prepričajte se da v bližini ni vnetljivih materialov.

HRUP - Lahko poškoduje sluh.

- Zaščitite ušesa. Uporablajte za to predpisano zaščitno opremo.
- Opozorite osebe v bližini na nevarnost

OKVARA - V primeru okvare pokličite strokovno pomoč.

PRED NAMEŠČANJEM IN UPORABO PREBERITE IN UPOŠTEVAJTE NAVODILA ZA UPORABO. ZAŠČITITE SEBE IN DRUGE!

OPOZORILO	Ne uporabljajte varilnega transformatorja za taljenje zamrznjenih cevi.
------------------	---

POZOR	Oprema razreda A ni namenjena za uporabo v stanovanjskih prostorih, kjer električno energijo zagotavlja javno niskonapetostno omrežje. V takih prostorih lahko pride do težav pri elektromagnetni združljivosti opreme razreda A zaradi prevodnih in sevalnih motenj.	
--------------	---	---

POZOR	Ta izdelek je namenjen samo rezanju s plazmo. Kakršna koli drugačna uporaba lahko povzroči osebne poškodbe in / ali poškodbe opreme.
--------------	--

POZOR	Pred nameščanjem in uporabo preberite in upoštevajte navodila za uporabo.	
--------------	---	---

AVSNITT 1: SÄKERHETSFÖRESKRIFTER

1.0 Säkerhetsföreskrifter

De som använder svets- och plasmaskärutrustning från ESAB ansvarar för att alla som arbetar med eller i närheten av utrustningen följer alla tillämpliga säkerhetsföreskrifter. Säkerhetsföreskrifterna måste uppfylla kraven som gäller denna typ av svets- eller plasmaskärutrustning. Följande rekommendationer ska följas, utöver de standardregler som gäller på arbetsplatsen.

Allt arbete måste utföras av utbildad personal som är väl förtrogen med svets- eller plasmaskärutrustningen. Felaktig användning av utrustningen kan leda till farliga situationer som kan orsaka personskador och skada utrustningen.

1. Alla som använder svets- eller plasmaskärutrustning måste känna till:
 - hur utrustningen används
 - nödstoppens placering
 - utrustningens funktion
 - tillämpliga säkerhetsföreskrifter
 - svetsning och/eller plasmaskärning
2. Operatören måste kontrollera att:
 - inga obehöriga personer befinner sig inom utrustningens arbetsområde när den startas.
 - ingen är oskyddad när bågen tänds.
3. Arbetsplatsen måste:
 - vara lämplig för ändamålet
 - vara fri från drag
4. Personlig säkerhetsutrustning:
 - Använd alltid rekommenderad personlig säkerhetsutrustning, till exempel skyddsglasögon, brandhårdiga kläder och säkerhetshandskar.
 - Använd inte löst sittande kläder, till exempel halsdukar, armband eller ringar, som kan fastna eller orsaka brännskador.
5. Allmänna försiktighetsåtgärder:
 - Kontrollera att återledaren är ordentligt fastsatt.
 - Arbeten på elektriska utrustningar **får bara utföras av behörig elektriker.**
 - Lämplig brandsläckningsutrustning ska finnas till hands och vara tydligt märkt.
 - Utför inte smörjning och underhåll på utrustningen under drift.



Kasserad elektronisk utrustning ska lämnas till återvinning!

Enligt direktiv 2012/19/EG om avfallshantering av elektrisk och elektronisk utrustning och dess genomförande i enlighet med nationell lag, ska elektrisk och elektronisk utrustning som nått slutet av sin livslängd samlas in separat och lämnas till återvinningsanläggning.

Det åvilar den som äger och/eller ansvarar för utrustningen att hålla sig informerad om vilka återvinningsanläggningar som är godkända.

För mer information, kontakta närmaste ESAB-återförsäljare.

ESAB kan leverera alla nödvändiga skydd och tillbehör för svetsning.

ESAB CUTMASTER 120

VARNING

SVETSNING OCH PLASMASKÄRNING KAN VARA FARLIGT FÖR DIG SJÄLV OCH ANDRA. VIDTA FÖRSIKTIGHETSÅTGÄRDER NÄR DU SVETSAR OCH SKÄR. DIN ARBETSGIVARE BÖR UTFORMA SÄKERHETSREGLER SOM SKA VARA BASERADE PÅ TILLVERKARENS RISKINFORMATION.

ELEKTRISKA STÖTAR är livsfarliga.

- Installera och jorda svets- eller plasmaskärutrustningen enligt gällande bestämmelser.
- Berör inte edande elektriska delar eller elektroder med bara händer, våta handskar eller våta kläder.
- Se till att du är isolerad mot marken och arbetsstycket.
- Se till att din arbetsställning är säker.

ÅNGOR OCH GASER - kan vara hälsovådliga.

- Undvik att andas in röken.
- Använd allmänventilation eller punktutdrag, eller båda, för att ta bort rök och gaser från arbetsområdet och hela lokalen.

BÅGSTRÅLAR - kan skada ögon och bränna huden.

- Skydda ögon och hud. Använd rätt utrustning för svetsning/plasmaskärning, till exempel skärm med filter och skyddskläder.
- Skydda personer i omgivningen med lämpliga skärmar eller draperier.

BRANDFARA

- Gnistor (stänk) kan orsaka eldsvåda. Kontrollera att det inte finns antändliga material i närheten.

BULLER - Kraftigt buller kan skada din hörsel.

- Skydda öronen. Använd öronproppar eller hörselskydd.
- Varna personer i närheten för bullerrisken.

FUNKTIONSFEL - tillkalla experthjälp vid funktionsfel.

**LÄS OCH FÖRSTÅ BRUKSANVISNINGEN INNAN DU INSTALLERAR ELLER ANVÄNDER ENHETEN.
SKYDDA DIG SJÄLV OCH ANDRA!**

VARNING

Använd inte strömkällan för att tina frusna rör.

Försiktighet

Utrustning klass A är inte avsedd för användning i bostadsområden där elförsörjningen sker via det publika lågspänningsdistributionsnätet. På grund av såväl ledningsburna som utstrålade störningar kan det i sådana områden vara problematiskt att uppnå elektromagnetisk kompatibilitet för utrustning klass A.

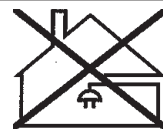

Försiktighet

Denna produkt är endast avsedd att användas till plasmaskärning. Annan användning kan resultera i personskada och/eller skada av utrustningen.

Försiktighet

Läs och förstå bruksanvisningen innan du installerar eller använder enheten.



This page intentionally blank.

SECTION 2 SYSTEM: INTRODUCTION

2.01 How To Use This Manual

This Owner's Manual applies to just specification or part numbers listed on page i.

To ensure safe operation, read the entire manual, including the chapter on safety instructions and warnings.

Throughout this manual, the words DANGER, WARNING, CAUTION, and NOTE may appear. Pay particular attention to the information provided under these headings. These special annotations are easily recognized as follows:

	<p>NOTE! An operation, procedure, or background information which requires additional emphasis or is helpful in efficient operation of the system.</p>
	<p>CAUTION A procedure which, if not properly followed, may cause damage to the equipment.</p>
	<p>WARNING A procedure which, if not properly followed, may cause injury to the operator or others in the operating area.</p>
	<p>WARNING Gives information regarding possible electrical shock injury. Warnings will be enclosed in a box such as this.</p>
	<p>DANGER Means immediate hazards which, if not avoided, will result in immediate, serious personal injury or loss of life.</p>

Additional copies of this manual may be purchased by contacting ESAB at the address and phone number in your area listed on back cover of this manual. Include the Owner's Manual number and equipment identification numbers.

Electronic copies of this manual can also be downloaded at no charge in Acrobat PDF format by going to the ESAB web site listed below

<http://www.esab.eu>

2.02 Equipment Identification

The unit's identification number (specification or part number), model, and serial number usually appear on a data tag attached to the rear panel. Equipment which does not have a data tag such as torch and cable assemblies are identified only by the specification or part number printed on loosely attached card or the shipping container. Record these numbers on the bottom of page i for future reference.

2.03 Receipt Of Equipment

When you receive the equipment, check it against the invoice to make sure it is complete and inspect the equipment for possible damage due to shipping. If there is any damage, notify the carrier immediately to file a claim. Furnish complete information concerning damage claims or shipping errors to the location in your area listed in the inside back cover of this manual.

Include all equipment identification numbers as described above along with a full description of the parts in error.

Move the equipment to the installation site before un-crating the unit. Use care to avoid damaging the equipment when using bars, hammers, etc., to un-crate the unit.

ESAB CUTMASTER 120

2.04 Power Supply Specifications

ESAB Cutmaster 120 Power Supply Specifications					
Input Power	400 VAC (360 - 440 VAC), Three Phase, 50/60 Hz				
Input Power Cable	Power Supply includes input cable.				
Output Current	30 - 120 Amps, Continuously Adjustable				
Power Supply Gas Filtering Ability	Particulates to 5 Microns				
ESAB Cutmaster 120 Power Supply Duty Cycle *					
Ambient Temperature	Duty Cycle Ratings @ 40° C (104° F) Operating Range 0° - 50° C				
All Units	Duty Cycle	N/A	40%		
	Ratings		IEC	CE	
	Current		120	120	
	DC Voltage		128	128	
* NOTE: The duty cycle will be reduced if the primary input power (AC) is low or the output voltage (DC) is higher than shown in this chart.					



NOTE!

IEC Rating is determined as specified by the International Electro-Technical Commission. These specifications include calculating an output voltage based upon power supply rated current. To facilitate comparison between power supplies, all manufacturers use this output voltage to determine duty cycle.

Power Supply Dimensions & Weight

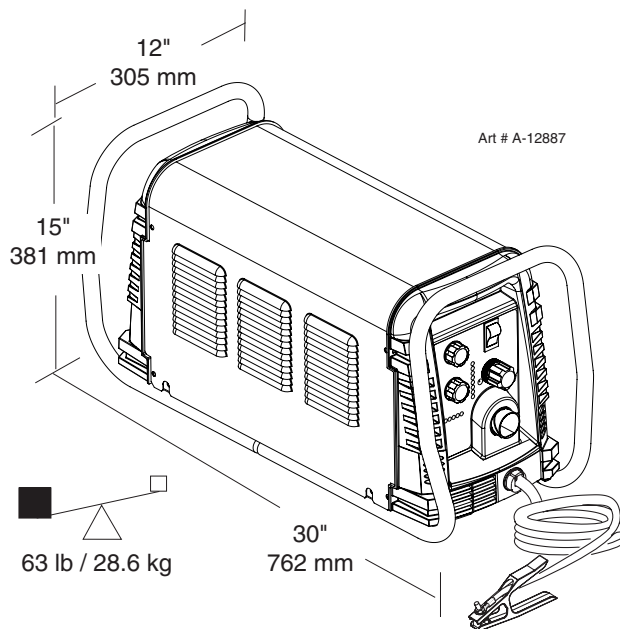

Ventilation Clearance Requirements

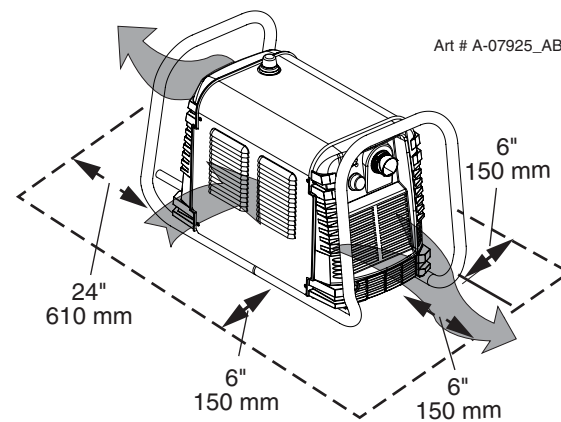

2.05 Input Wiring Specifications

ESAB Cutmaster 120 Power Supply Input Cable Wiring Requirements								
	Input voltage	Freq	Power Input			Suggested Sizes		
	Volts	Hz	kVA	I max	I eff	Fuse (amps)	Flexible Cord (Min. AWG)	Flexible Cord (Min. mm ²)
3 Phase	400	50	23.6	34	31	40	8	10
Line Voltages with Suggested Circuit Protection and Wire Sizes Based on National Electric Code and Canadian Electric Code								

 **NOTE!**
 Refer to Local and National Codes or local authority having jurisdiction for proper wiring requirements.
 The suggested sizes are based on flexible power cable with power plug installations. For hard-wired installations refer to local or national codes.
 I_{1max} is taken at TDC rated minimum duty cycle.
 I_{1eff} is taken at TDC 100% rated duty cycle.

ESAB CUTMASTER 120

2.06 Power Supply Features

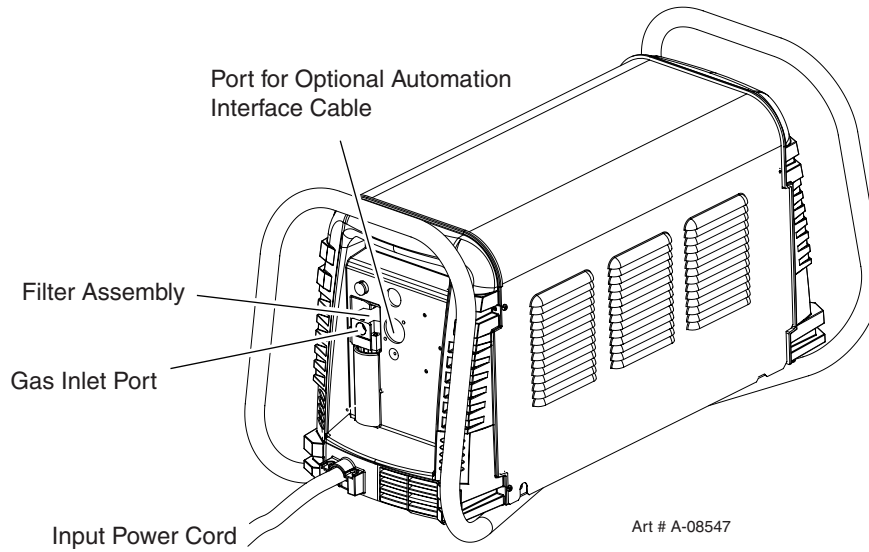
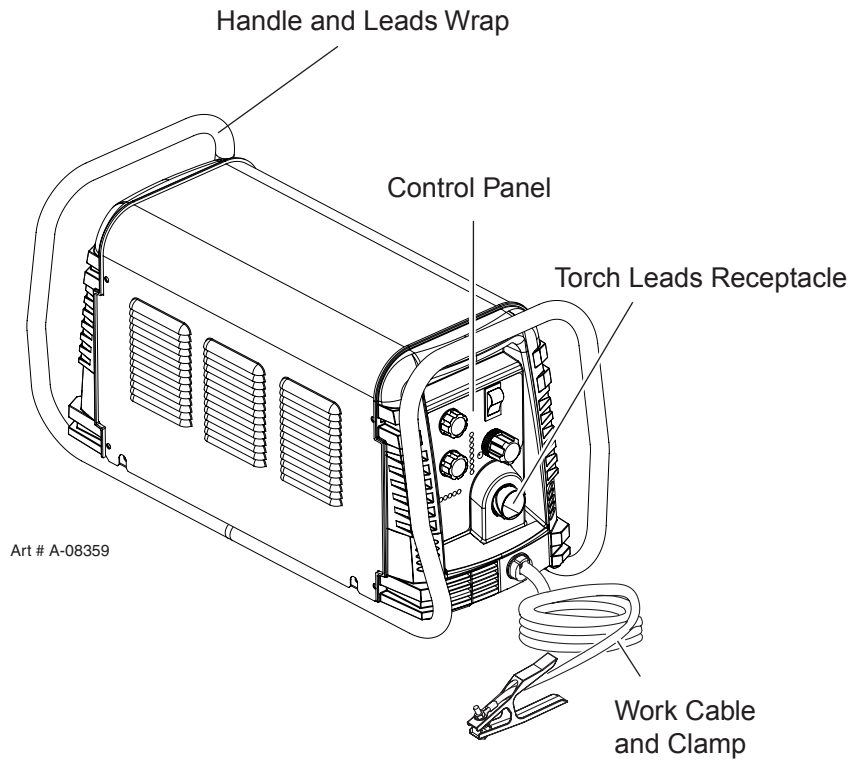

SECTION 2 TORCH: INTRODUCTION

2T.01 Scope of Manual

This manual contains descriptions, operating instructions and maintenance procedures for the 1Torch Models SL100/Manual and SL100/Mechanized Plasma Cutting Torches. Service of this equipment is restricted to properly trained personnel; unqualified personnel are strictly cautioned against attempting repairs or adjustments not covered in this manual, at the risk of voiding the Warranty.

Read this manual thoroughly. A complete understanding of the characteristics and capabilities of this equipment will assure the dependable operation for which it was designed.

2T.02 General Description

Plasma torches are similar in design to the automotive spark plug. They consist of negative and positive sections separated by a center insulator. Inside the torch, the pilot arc starts in the gap between the negatively charged electrode and the positively charged tip. Once the pilot arc has ionized the plasma gas, the superheated column of gas flows through the small orifice in the torch tip, which is focused on the metal to be cut.

A single torch lead provides gas from a single source to be used as both the plasma and secondary gas. The air flow is divided inside the torch head. Single - gas operation provides a smaller sized torch and inexpensive operation.



NOTE!

Refer to Section "2T.05 Introduction to Plasma", for a more detailed description of plasma torch operation. Refer to the Appendix Pages for additional specifications as related to the Power Supply used.

2T.03 Specifications

A. Torch Configurations

1. Hand/Manual Torch, Models

The hand torch head is at 75° to the torch handle. The hand torches include a torch handle and torch trigger assembly.

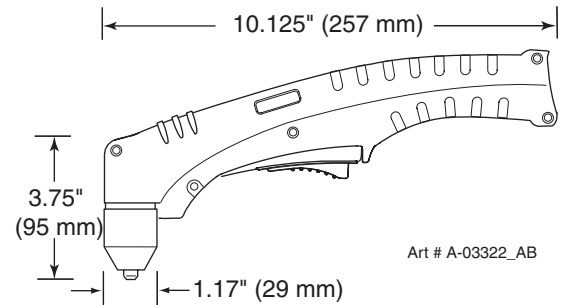

2. Mechanized Torch, Model

The standard machine torch has a positioning tube with rack & pinch block assembly.

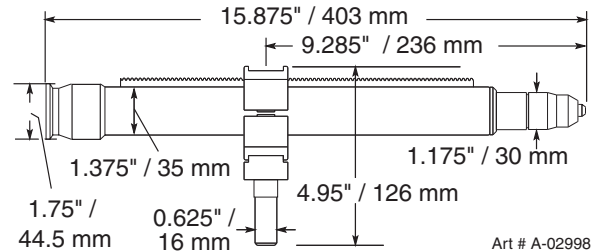

B. Torch Leads Lengths

Hand Torches are available as follows:

- 20 ft / 6.1 m, with ATC connectors
- 50 ft / 15.2 m, with ATC connectors

Machine Torches are available as follows:

- 5 foot / 1.5 m, with ATC connectors
- 10 foot / 3.05 m, with ATC connectors
- 25 foot / 7.6 m, with ATC connectors
- 50 foot / 15.2 m, with ATC connectors

C. Torch Parts

Starter Cartridge, Electrode, Tip, Shield Cup

D. Parts - In - Place (PIP)

Torch Head has built - in switch

12 VDC circuit rating

E. Type Cooling

Combination of ambient air and gas stream through torch.

ESAB CUTMASTER 120

F. Torch Ratings

Manual Torch Ratings	
Ambient Temperature	104° F 40° C
Duty Cycle	100% @ 120 Amps @ 400 scfh
Maximum Current	120 Amps
Voltage (V _{peak})	500V
Arc Striking Voltage	7kV

Mechanized Torch Ratings	
Ambient Temperature	104° F 40° C
Duty Cycle	100% @ 120 Amps @ 400 scfh
Maximum Current	120 Amps
Voltage (V _{peak})	500V
Arc Striking Voltage	7kV

G. Gas Requirements

Manual and Mechanized Torch Gas Specifications	
Gas (Plasma and Secondary)	Compressed Air
Operating Pressure Refer to NOTE	60 - 95 psi 4.1 - 6.5 bar
Maximum Input Pressure	125 psi / 8.6 bar
Gas Flow (Cutting and Gouging)	300 - 500 scfh 142 - 235 lpm



WARNING

This torch is not to be used with oxygen (O₂)



NOTE!

Operating pressure varies with torch model, operating amperage, and torch leads length. Refer to gas pressure settings charts for each model.

H. Direct Contact Hazard

For standoff tip the recommended standoff is 3/16 inches / 4.7 mm.

2T.04 Options And Accessories

For options and accessories, see section 6.

2T.05 Introduction to Plasma

A. Plasma Gas Flow

Plasma is a gas which has been heated to an extremely high temperature and ionized so that it becomes electrically conductive. The plasma arc cutting and gouging processes use this plasma to transfer an electrical arc to the workpiece. The metal to be cut or removed is melted by the heat of the arc and then blown away.

While the goal of plasma arc cutting is separation of the material, plasma arc gouging is used to remove metals to a controlled depth and width.

In a Plasma Cutting Torch a cool gas enters Zone B, where a pilot arc between the electrode and the torch tip heats and ionizes the gas. The main cutting arc then transfers to the workpiece through the column of plasma gas in Zone C.

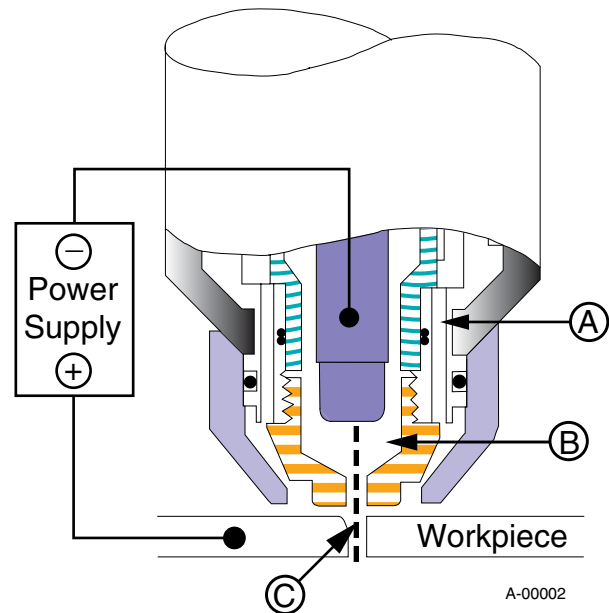

Typical Torch Head Detail

By forcing the plasma gas and electric arc through a small orifice, the torch delivers a high concentration of heat to a small area. The stiff, constricted plasma arc is shown in Zone C. Direct current (DC) straight polarity is used for plasma cutting, as shown in the illustration.

Zone A channels a secondary gas that cools the torch. This gas also assists the high velocity plasma gas in blowing the molten metal out of the cut allowing for a fast, slag - free cut.

B. Gas Distribution

The single gas used is internally split into plasma and secondary gases.

ESAB CUTMASTER 120

The plasma gas flows into the torch through the negative lead, through the starter cartridge, around the electrode, and out through the tip orifice.

The secondary gas flows down around the outside of the torch starter cartridge, and out between the tip and shield cup around the plasma arc.

C. Pilot Arc

When the torch is started a pilot arc is established between the electrode and cutting tip. This pilot arc creates a path for the main arc to transfer to the work.

D. Main Cutting Arc

DC power is also used for the main cutting arc. The negative output is connected to the torch electrode through the torch lead. The positive output is connected to the workpiece via the work cable and to the torch through a pilot wire.

E. Parts - In - Place (PIP)

The torch includes a 'Parts - In - Place' (PIP) circuit. When the shield cup is properly installed, it closes a switch. The torch will not operate if this switch is open.

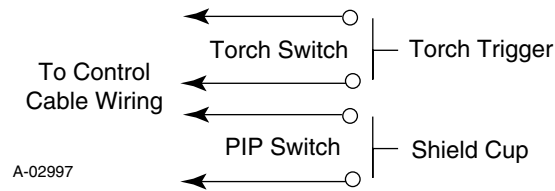

Parts - In - Place Circuit Diagram for Hand Torch

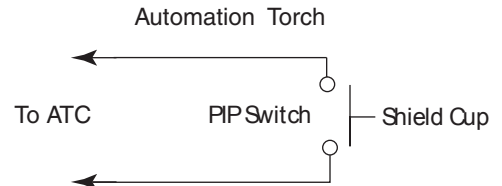
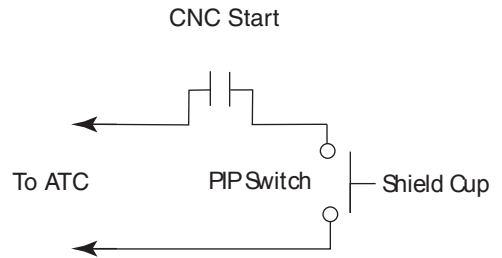
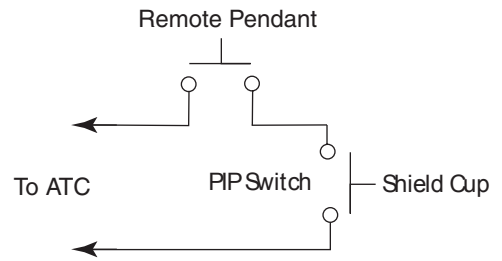

Parts - In - Place Circuit Diagram for Machine Torch

Art# A-08168

This Page Intentionally Blank

SECTION 3 SYSTEM: INSTALLATION

3.01 Unpacking

1. Use the packing lists to identify and account for each item.
2. Inspect each item for possible shipping damage. If damage is evident, contact your distributor and / or shipping company before proceeding with the installation.
3. Record Power Supply and Torch model and serial numbers, purchase date and vendor name, in the information block at the front of this manual.

3.02 Lifting Options

The Power Supply includes a handle for **hand lifting only**. Be sure unit is lifted and transported safely and securely.



WARNING

Do not touch live electrical parts. Disconnect input power cord before moving unit.



WARNING

FALLING EQUIPMENT can cause serious personal injury and can damage equipment. HANDLE is not for mechanical lifting.

- Only persons of adequate physical strength should lift the unit.
- Lift unit by the handles, using two hands. Do not use straps for lifting.
- Use optional cart or similar device of adequate capacity to move unit.
- Place unit on a proper skid and secure in place before transporting with a fork lift or other vehicle.

3.03 Primary Input Power Connections



CAUTION

Check your power source for correct voltage before plugging in or connecting the unit. The primary power source, fuse, and any extension cords used must conform to local electrical code and the recommended circuit protection and wiring requirements as specified in Section 2.

The following illustration and directions are for wiring three phase input power.

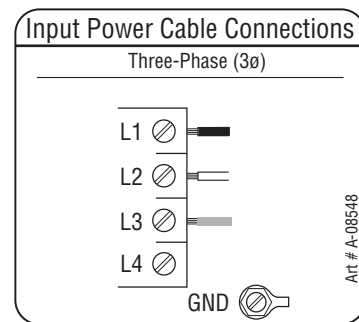

Three Phase Input Power Wiring

A. Connections to Three Phase Input Power



WARNING

Disconnect input power from the power supply and input cable before attempting this procedure.

These instructions are for replacing the input power and or cable for 400 VAC Power Supply to Three - Phase input power.

1. Remove the Power Supply cover per instructions found in section 5.
2. Disconnect the original input power cable from the main input contactor and the chassis ground connection.
3. Loosen the through - hole protector on the back panel of the power supply. Pull the original power cable out of the power supply.
4. Using a customer supplied four - conductor input power cable for the voltage desired, strip back the insulation on the individual wires.
5. Pass the cable being used through the access opening in the back panel of the power supply. Refer to Section 2 for power cable specifications.

ESAB CUTMASTER 120



CAUTION

The primary power source and power cable must conform to local electrical code and the recommended circuit protection and wiring requirements (refer to table in Section 2).

6. Connect the wires as follows.
 - Wires to L1, L2 and L3 input. It does not matter what order these wires are attached. See previous illustration and on label in the power supply.
 - Green / Yellow wire to Ground.
7. With a little slack in the wires, tighten the through-hole protector to secure the power cable.
8. Reinstall the Power Supply cover per instructions found in section 5.
9. Connect the opposite end of individual wires to a customer supplied plug or main disconnect.
10. Connect the input power cable (or close the main disconnect switch) to supply power.

3.04 Gas Connections

Connecting Gas Supply to Unit

The connection is the same for compressed air or high pressure cylinders. Refer to the following two subsections if an optional air line filter is to be installed.

1. Connect the air line to the inlet port. The illustration shows typical fittings as an example.



NOTE!

For a secure seal, apply thread sealant to the fitting threads, according to manufacturer's instructions. Do not use Teflon tape as a thread sealer, as small particles of the tape may break off and block the small air passages in the torch.

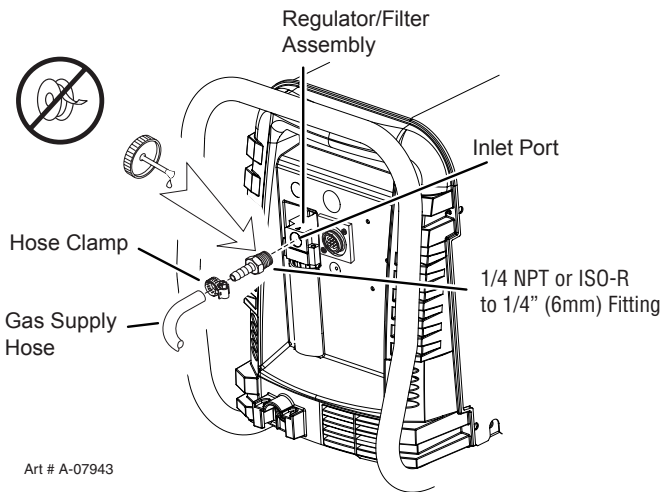

Air Connection to Inlet Port

Installing Optional Single - Stage Air Filter

An optional filter kit is recommended for improved filtering with compressed air, to keep moisture and debris out of the torch.

1. Attach the Single - Stage Filter Hose to the Inlet Port.
2. Attach the Filter Assembly to the filter hose.
3. Connect the air line to the Filter. The illustration shows typical fittings as an example.



NOTE!

For a secure seal, apply thread sealant to the fitting threads, according to the maker's instructions. Do Not use Teflon tape as a thread sealer, as small particles of the tape may break off and block the small air passages in the torch. Connect as follows:

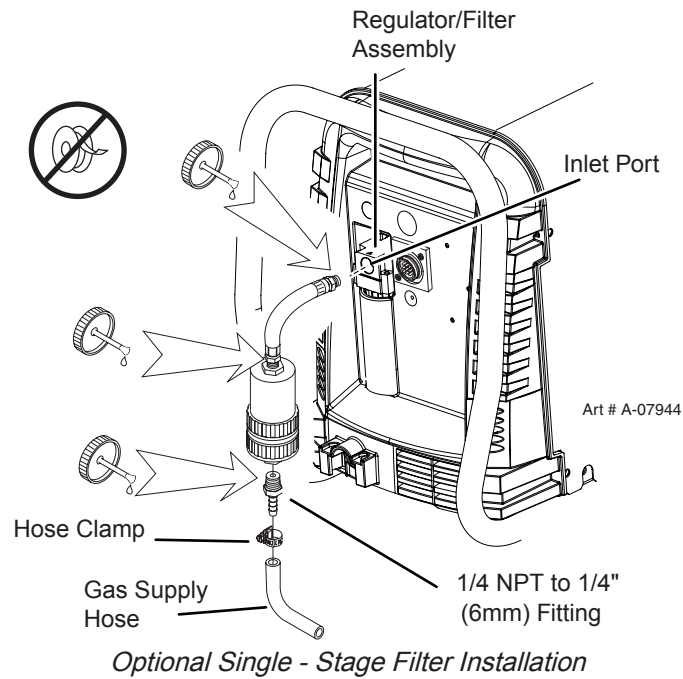

Installing Optional Two - Stage Air Filter Kit

This optional two - stage air line filter is also for use on compressed air shop systems. Filter removes moisture and contaminants to at least 5 microns.

Connect the air supply as follows:

1. Attach the Two Stage Filter bracket to the back of the power supply per instructions supplied with the filter assembly.

ESAB CUTMASTER 120



NOTE!

For a secure seal, apply thread sealant to the fitting threads according to manufacturer's instructions. Do Not use Teflon tape as a thread sealer as small particles of the tape may break off and block the small air passages in the torch.

2. Connect the two stage filter outlet hose to the inlet port of the Regulator / Filter Assembly.
3. Use customer - supplied fittings to connect the air line to the Filter. A 1/4 NPT to 1/4" hose barbed fitting is shown as an example.

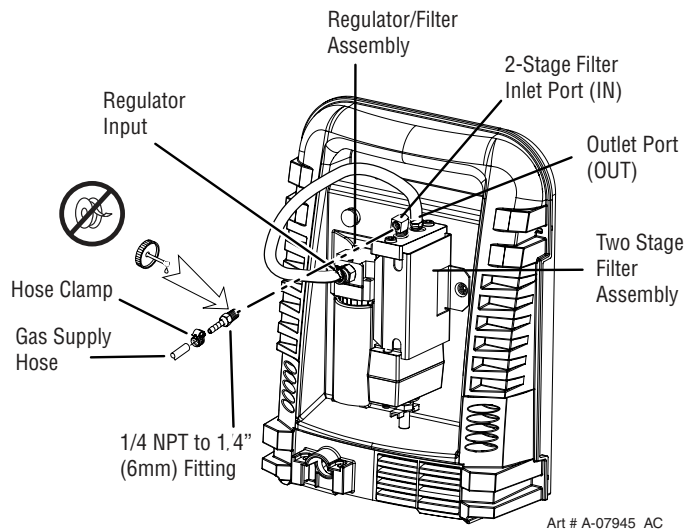

Optional Two - Stage Filter Installation

Using High Pressure Air Cylinders

When using high pressure air cylinders as the air supply:

1. Refer to the manufacturer's specifications for installation and maintenance procedures for high pressure regulators.
2. Examine the cylinder valves to be sure they are clean and free of oil, grease or any foreign material. Briefly open each cylinder valve to blow out any dust which may be present.
3. The cylinder must be equipped with an adjustable high - pressure regulator capable of outlet pressures up to 100 psi (6.9 bar) maximum and flows of at least 300 scfh (141.5 lpm).
4. Connect supply hose to the cylinder.



NOTE!

Pressure should be set at 100 psi (6.9 bar) at the high pressure cylinder regulator.

Supply hose must be at least 1/4 inch (6 mm) I.D.

For a secure seal, apply thread sealant to the fitting threads, according to manufacturer's instructions. Do Not use Teflon tape as a thread sealer, as small particles of the tape may break off and block the small air passages in the torch.

SECTION 3 TORCH: INSTALLATION

3T.02 Setting Up Mechanical Torch

3T.01 Torch Connections

If necessary, connect the torch to the Power Supply. Connect only the ESAB model SL100 / Manual or SL100 / Mechanical Torch to this power supply. Maximum torch leads length is 100 feet / 30.5 m, including extensions.

 **WARNING**
Disconnect primary power at the source before connecting the torch.

1. Align the ATC male connector (on the torch lead) with the female receptacle. Push the male connector into the female receptacle. The connectors should push together with a small amount of pressure.
2. Secure the connection by turning the locking nut clockwise until it clicks. **DO NOT** use the locking nut to pull the connection together. Do not use tools to secure the connection.

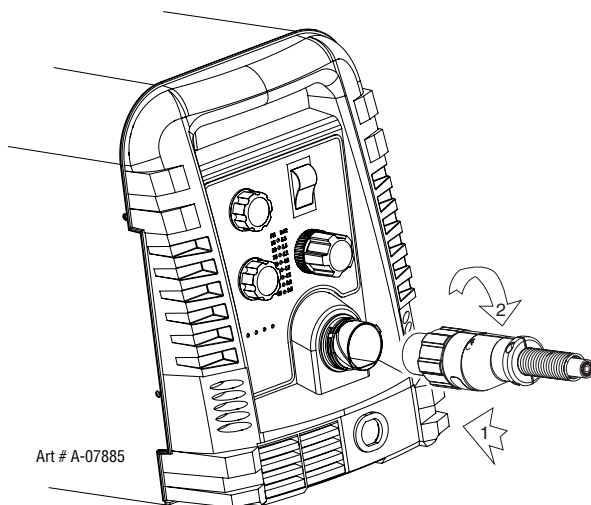



Art # A-07885
Connecting the Torch to the Power Supply

3. The system is ready for operation.

Check Air Quality

To test the quality of air:

1.  Put the ON / OFF switch in the ON (up) position.
2. Put the Function Control switch in the SET position. 
3. Place a welding filter lens in front of the torch and turn on the air. **Do not start an arc!**
Any oil or moisture in the air will be visible on the lens.



NOTE!

An adapter is required to be installed in the power supply if converting a hand torch system to operate a machine torch.



WARNING

Disconnect primary power at the source before connecting the torch.

The mechanical torch includes a positioning tube with rack and pinch block assembly.

1. Mount the torch assembly on the cutting table.
2. To obtain a clean vertical cut, use a square to align the torch perpendicular to the surface of the workpiece.

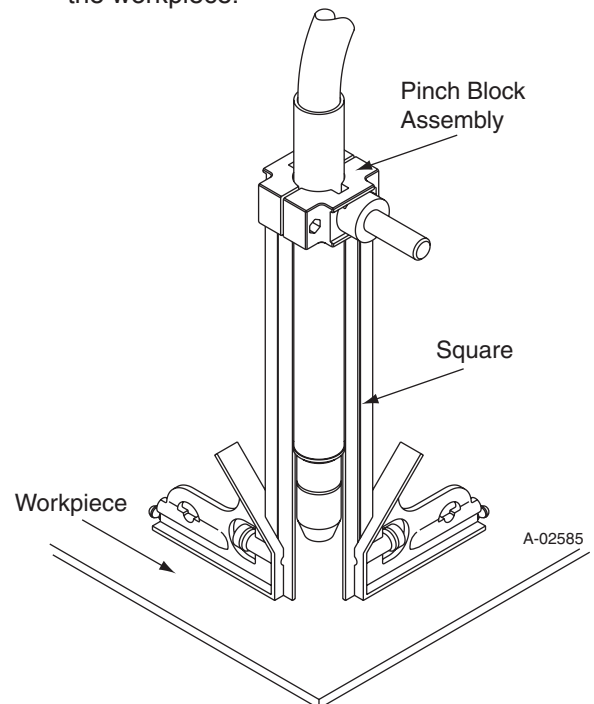

Mechanical Torch Set - Up

3. The proper torch parts (shield cup, tip, start cartridge, and electrode) must be installed for the type of operation. Refer to Section 4T.07, Torch Parts Selection for details.

This Page Intentionally Blank

SECTION 4 SYSTEM: OPERATION

4.01 Front Panel Controls / Features

See Illustration for numbering Identification

1. Output Current Control

Sets the desired output current. Output settings up to 60 Amps may be used for drag cutting (with the torch tip contacting the workpiece) or higher for standoff cutting.



2. Function Control

Function Control Knob, Used to select between the different operating modes.

 **SET** Used to purge the air through the unit and torch and leads and to adjust gas pressure.

 **RUN** Used for general cutting operations

 **RAPID AUTO RESTART** Allows for faster restarting of the Pilot Arc for uninterrupted cutting.

  **LATCH** Used for longer hand held cuts. Once a cutting arc is established, the torch switch can be released. The cutting arc will remain ON until the torch is lifted away from the work piece, the torch leaves the edge of the work piece the torch switch is activated again or if one of the system interlocks is activated.

3. ON OFF Power Switch

 ON / OFF Switch controls input power to the power supply. Up is ON, down is OFF.

4. Air/Gas Pressure Control

 The Pressure Control is used in the "SET" mode to adjust the air/gas pressure. Pull the knob out to adjust and push in to lock.

5. AC Indicator

Steady light indicates power supply is ready for operation. Blinking light indicates unit is in protective interlock mode. Shut unit OFF, shut OFF or discon-

nect input power, correct the fault, and restart the unit. Refer to Section 5 for details.

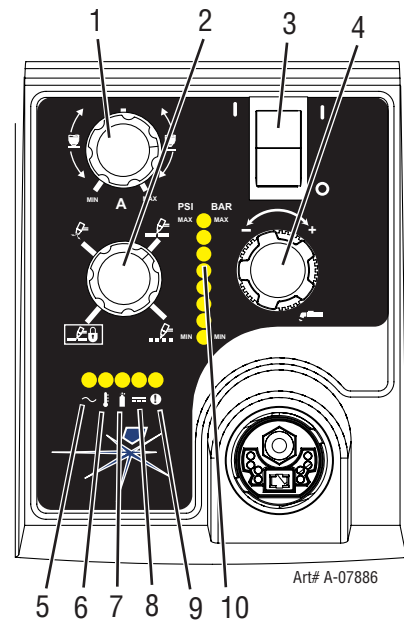

6. Temp Indicator

Indicator is normally OFF. Indicator is ON when internal temperature exceeds normal limits. Let the unit cool before continuing operation.

7. Gas Indicator

Indicator is ON when minimum input gas pressure for power supply operation is present. Minimum pressure for power supply operation is not sufficient for torch operation.

8. DC Indicator

Indicator is ON when DC output circuit is active.

9. Fault Error Indicator

Indicator is ON when Fault circuit is active. See section 5 for explanations of fault lights.

ESAB CUTMASTER 120

10. Pressure Indicators

PSI	BAR
MAX	MAX
90	6.3
85	5.9
80	5.5
75	5.2
70	4.8
65	4.5
MIN	MIN

Art # A-08170

The Indicators will illuminate according to the pressure set by the Pressure Control Knob (number 4).

4.02 Preparations for Operation

At the start of each operating session:



WARNING

Disconnect primary power at the source before assembling or disassembling power supply, torch parts, or torch and leads assemblies.

Torch Parts Selection

Check the torch for proper assembly and appropriate torch parts. The torch parts must correspond with the type of operation, and with the amperage output of this Power Supply (120 amps maximum). Refer to Section 4T.07 and following for torch parts selection.

Torch Connection

Check that the torch is properly connected. Only ESAB model SL100 / Manual or SL100 / Mechanical Torches may be connected to this Power Supply. See Section 3T of this manual.

Check Primary Input Power Source

1. Check the power source for proper input voltage. Make sure the input power source meets the power requirements for the unit per Section 2, Specifications.
2. Connect the input power cable (or close the main disconnect switch) to supply power to the system.

Air Source

Ensure source meets requirements (refer to Section 2). Check connections and turn air supply ON.

Connect Work Cable

Clamp the work cable to the workpiece or cutting table. The area must be free from oil, paint and rust. Connect only to the main part of the workpiece; do not connect to the part to be cut off.

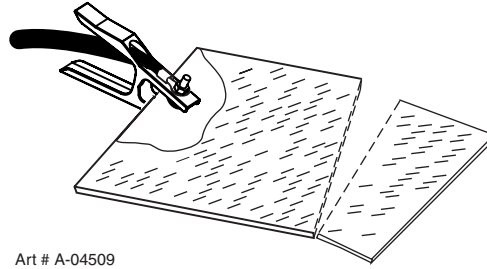

Art # A-04509

Power ON

Place the Power Supply ON / OFF switch to the **ON** (up) position.  AC indicator turns ON.



Gas indicator turns ON if there is sufficient gas pressure for power supply operation and the cooling fans turn ON.



NOTE!

Minimum pressure for power supply operation is lower than minimum for torch operation.

The cooling fans will turn ON as soon as the unit is turned ON. After the unit is idle for ten (10) minutes the fans will turn OFF. The fans will come back ON as soon as the torch switch (Start Signal) is activated or if the unit is turned off, then turned ON again. If an over temperature condition occurs, the fans will continue to run while the condition exists and for a ten (10) minute period once the condition is cleared.

Set Operating Pressure

1. Place the Power Supply Function Control knob to the SET position.  Gas will flow.
2. For Standoff cutting, adjust gas pressure from 70 - 85 psi / 4.8 - 5.9 bar (LED's in center of control panel). Refer to the Standoff chart for pressure setting details.

ESAB CUTMASTER 120

- Set the output current to desired amperage with the Output Current Control Knob.

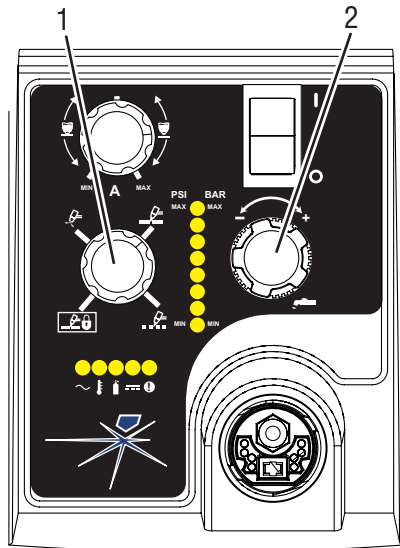

Art# A-07946

Cutting Operation

When the torch leaves the workpiece during cutting operations with the Function Control Knob in the RUN position, there is a brief delay in restarting the pilot arc. With the knob in the **RAPID AUTO RESTART** position, when the torch leaves the workpiece the pilot arc restarts instantly, and the cutting arc restarts instantly when the pilot arc contacts the workpiece. (Use the 'Rapid Auto Restart' position when cutting expanded metal or gratings, or in gouging or trimming operations when an uninterrupted restart is desired). And with the knob in the LATCH position the main cutting arc will be maintained after the torch switch is released.

Typical Cutting Speeds

Cutting speeds vary according to torch output amperage, the type of material being cut, and operator skill. Refer to Section 4T.08 and following for greater details.

Output current setting or cutting speeds may be reduced to allow slower cutting when following a line, or using a template or cutting guide while still producing cuts of excellent quality.

STANDOFF		
ESAB Cutmaster 120 Gas Pressure Settings		
Leads Length	SL100 (Hand Torch)	SL100 (Mechanized Torch) SL100 SV (Automation Torch)
Up to 50' (7.6 m)	75 psi 5.2 bar	75 psi 5.2 bar
Each additional 25' (7.6 m)	Add 5 psi 0.4 bar	Add 5 psi 0.4 bar

- For Drag cutting, adjust gas pressure from 75 - 95 psi / 5.2 - 6.5 bar (LED's in center of control panel). Refer to the Drag Cutting chart for pressure setting details.

DRAG (60 amps or less)	
ESAB Cutmaster 120 Gas Pressure Settings	
Leads Length	SL100 (Hand Torch)
Up to 25' (7.6 m)	80 psi 5.5 bar
Each additional 25' (7.6 m)	Add 5 psi 0.4 bar

Postflow

Release the trigger to stop the cutting arc. Gas continues to flow for approximately 20 seconds. During post - flow, if the user moves the trigger release to the rear and presses the trigger, the pilot arc starts. The main arc transfers to the workpiece if the torch tip is within transfer distance to the workpiece.

Shutdown

- Turn the ON / OFF switch to **OFF** (down).
- All Power Supply indicators shut OFF. Unplug the input power cord or disconnect input power. Power is removed from the system.

Select Current Output Level

- Place the Function Control Knob in one of the three operating positions available:

RUN,

RAPID AUTO RESTART,

or **LATCH.** Gas flow stops.

This Page Intentionally Blank

SECTION 4 TORCH: OPERATION

4T.01 Torch Parts Selection

Depending on the type of operation to be done determines the torch parts to be used.

Type of operation:

Drag cutting, standoff cutting or gouging

Torch parts:

Shield Cup, Cutting Tip, Electrode and Starter Cartridge



NOTE!

Refer to Section 4T.07 and following for additional information on torch parts.

Change the torch parts for a different operation as follows:



WARNING

Disconnect primary power at the source before assembling or disassembling power supply, torch parts, or torch and leads assemblies.



NOTE!

The shield cup holds the tip and starter cartridge in place. Position the torch with the shield cup facing upward to keep these parts from falling out when the cup is removed.

1. Unscrew and remove the shield cup assembly from the torch head.
2. Remove the Electrode by pulling it straight out of the Torch Head.

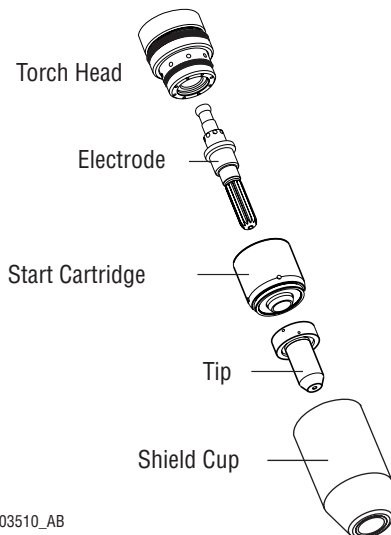

A-03510_AB

Torch Parts (Drag Shield Cap & Shield Cup Body Shown)

3. Install the replacement Electrode by pushing it straight into the torch head until it clicks.
4. Install the starter cartridge and desired tip for the operation into the torch head.
5. Hand tighten the shield cup assembly until it is seated on the torch head. If resistance is felt when installing the cup, check the threads before proceeding.

4T.02 Cut Quality



NOTE!

Cut quality depends heavily on setup and parameters such as torch standoff, alignment with the work-piece, cutting speed, gas pressures, and operator ability.

Cut quality requirements differ depending on application. For instance, nitride build - up and bevel angle may be major factors when the surface will be welded after cutting. Dross - free cutting is important when finish cut quality is desired to avoid a secondary cleaning operation. The following cut quality characteristics are illustrated in the following figure:

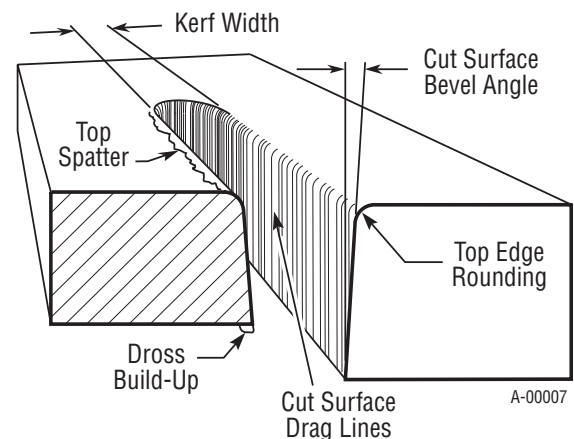

A-00007

Cut Quality Characteristics

Cut Surface

The desired or specified condition (smooth or rough) of the face of the cut.

Nitride Build - Up

Nitride deposits can be left on the surface of the cut when nitrogen is present in the plasma gas stream. These buildups may create difficulties if the material is to be welded after the cutting process.

ESAB CUTMASTER 120

Bevel Angle

The angle between the surface of the cut edge and a plane perpendicular to the surface of the plate. A perfectly perpendicular cut would result in a 0° bevel angle.

Top - Edge Rounding

Rounding on the top edge of a cut due to wearing from the initial contact of the plasma arc on the workpiece.

Bottom Dross Buildup

Molten material which is not blown out of the cut area and resolidifies on the plate. Excessive dross may require secondary cleanup operations after cutting.

Kerf Width

The width of the cut (or the width of material removed during the cut).

Top Spatter (Dross)

Top spatter or dross on the top of the cut caused by slow travel speed, excess cutting height, or cutting tip whose orifice has become elongated.

4T.03 General Cutting Information



WARNING

Disconnect primary power at the source before disassembling the power supply, torch, or torch leads. Frequently review the Important Safety Precautions at the front of this manual. Be sure the operator is equipped with proper gloves, clothing, eye and ear protection. Make sure no part of the operator's body comes into contact with the workpiece while the torch is activated.



CAUTION

Sparks from the cutting process can cause damage to coated, painted, and other surfaces such as glass, plastic and metal.



NOTE!

Handle torch leads with care and protect them from damage.

Piloting

Piloting is harder on parts life than actual cutting because the pilot arc is directed from the electrode to the tip rather than to a workpiece. Whenever possible, avoid excessive pilot arc time to improve parts life.

Torch Standoff

Improper standoff (the distance between the torch tip and workpiece) can adversely affect tip life as well as shield cup life. Standoff may also significantly affect the bevel angle. Reducing standoff will generally result in a more square cut.

Edge Starting

For edge starts, hold the torch perpendicular to the workpiece with the front of the tip near (not touching) the edge of the workpiece at the point where the cut is to start. When starting at the edge of the plate, do not pause at the edge and force the arc to "reach" for the edge of the metal. Establish the cutting arc as quickly as possible.

Direction of Cut

In the torches, the plasma gas stream swirls as it leaves the torch to maintain a smooth column of gas. This swirl effect results in one side of a cut being more square than the other. Viewed along the direction of travel, the right side of the cut is more square than the left.

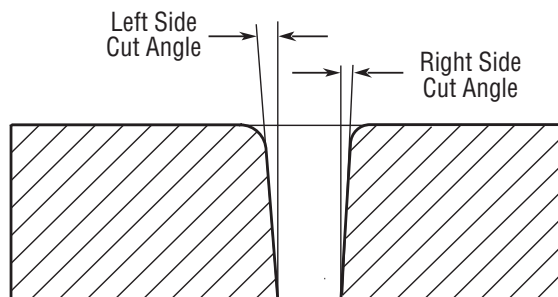

Side Characteristics Of Cut

To make a square - edged cut along an inside diameter of a circle, the torch should move counterclockwise around the circle. To keep the square edge along an outside diameter cut, the torch should travel in a clockwise direction.

Dross

When dross is present on carbon steel, it is commonly referred to as either "high speed, slow speed, or top dross". Dross present on top of the plate is normally caused by too great a torch to plate distance. "Top dross" is normally very easy to remove

and can often be wiped off with a welding glove. "Slow speed dross" is normally present on the bottom edge of the plate. It can vary from a light to heavy bead, but does not adhere tightly to the cut edge, and can be easily scraped off. "High speed dross" usually forms a narrow bead along the bottom of the cut edge and is very difficult to remove. When cutting a troublesome steel, it is sometimes useful to reduce the cutting speed to produce "slow speed dross". Any resultant cleanup can be accomplished by scraping, not grinding.

4T.04 Hand Torch Operation

Standoff Cutting With Hand Torch



NOTE!

For best parts performance and life, always use the correct parts for the type of operation.

1. The torch can be comfortably held in one hand or steadied with two hands. Position the hand to press the Trigger on the torch handle. With the hand torch, the hand may be positioned close to the torch head for maximum control or near the back end for maximum heat protection. Choose the holding technique that feels most comfortable and allows good control and movement.



NOTE!

The tip should never come in contact with the workpiece except during drag cutting operations.

2. Depending on the cutting operation, do one of the following:
 - a. For **edge starts**, hold the torch perpendicular to the workpiece with the front of the tip on the edge of the workpiece at the point where the cut is to start.
 - b. For **standoff cutting**, hold the torch 1/8 - 3/8 in (3-9 mm) from the workpiece as shown below.

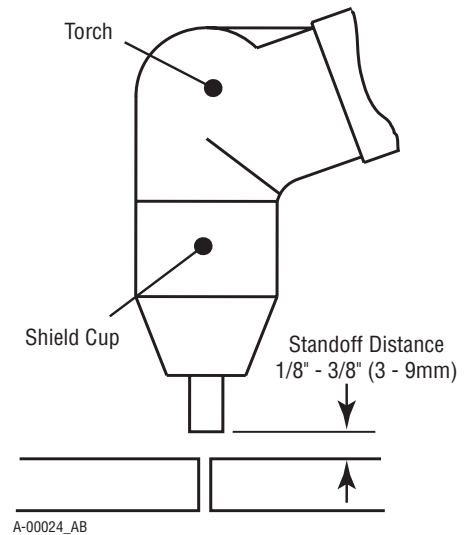

Standoff Distance

3. Hold the torch away from your body.
4. Slide the trigger release toward the back of the torch handle while simultaneously squeezing the trigger. The pilot arc will start.

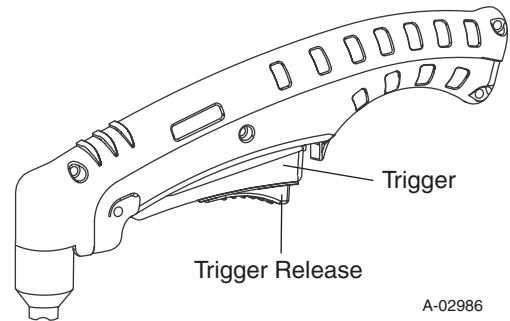

5. Bring the torch within transfer distance to the work. The main arc will transfer to the work, and the pilot arc will shut off.



NOTE!

The gas preflow and postflow are a characteristic of the power supply and not a function of the torch.

ESAB CUTMASTER 120

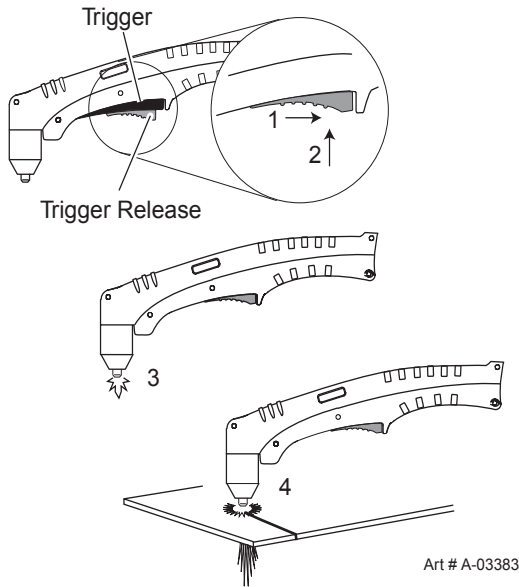

6. Cut as usual. Simply release the trigger assembly to stop cutting.
7. Follow normal recommended cutting practices as provided in the power supply operator's manual.



NOTE!

When the shield cup is properly installed, there is a slight gap between the shield cup and the torch handle. Gas vents through this gap as part of normal operation. Do not attempt to force the shield cup to close this gap. Forcing the shield cup against the torch head or torch handle can damage components.

8. For a consistent standoff height from the workpiece, install the standoff guide by sliding it onto the torch shield cup. Install the guide with the legs at the sides of the shield cup body to maintain good visibility of the cutting arc. During operation, position the legs of the standoff guide against the workpiece.

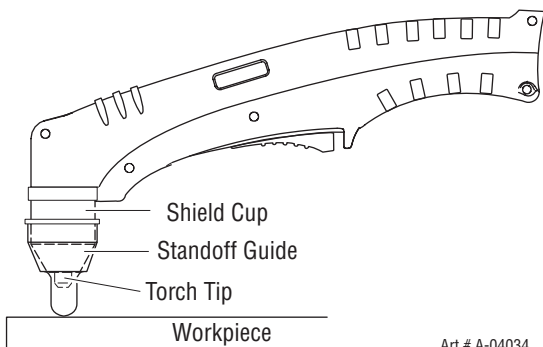

Shield Cup With Straight Edge

The drag shield cup can be used with a non conductive straight edge to make straight cuts by hand.



WARNING

The straight edge **must be** non-conductive.

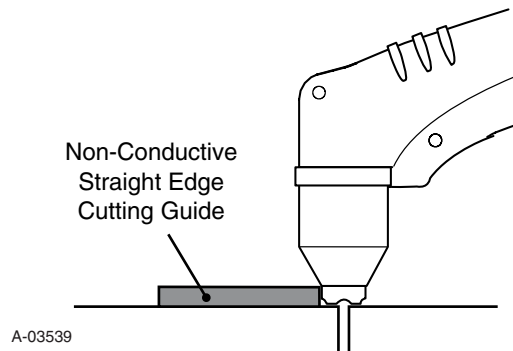

Using Drag Shield Cup With Straight Edge

The crown shield cup functions best when cutting 3/16 inch (4.7 mm) solid metal with relatively smooth surface.

Drag Cutting With a Hand Torch

Drag cutting works best on metal 1/4" (6 mm) thick or less.



NOTE!

Drag cutting can only be performed at 60 amps or less. For best parts performance and life, always use the correct parts for the type of operation.

1. Install the drag cutting tip and set the output current.
2. The torch can be comfortably held in one hand or steadied with two hands. Position the hand to press the Trigger on the torch handle. With the hand torch, the hand may be positioned close to the torch head for maximum control or near the back end for maximum heat protection. Choose the holding technique that feels most comfortable and allows good control and movement.
3. Keep the torch in contact with the workpiece during the cutting cycle.
4. Hold the torch away from your body.
5. Slide the trigger release toward the back of the torch handle while simultaneously squeezing the trigger. The pilot arc will start.

Piercing With Hand Torch

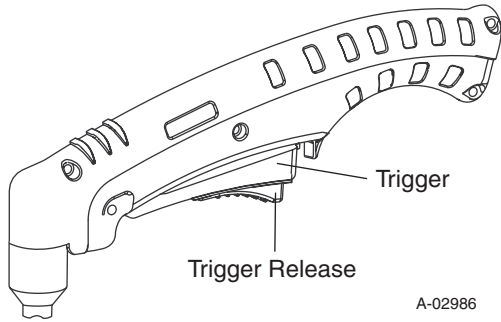

- Bring the torch within transfer distance to the work. The main arc will transfer to the work, and the pilot arc will shut off.



NOTE!

The gas preflow and postflow are a characteristic of the power supply and not a function of the torch.



NOTE!

The tip should never come in contact with the workpiece except during drag cutting operations.

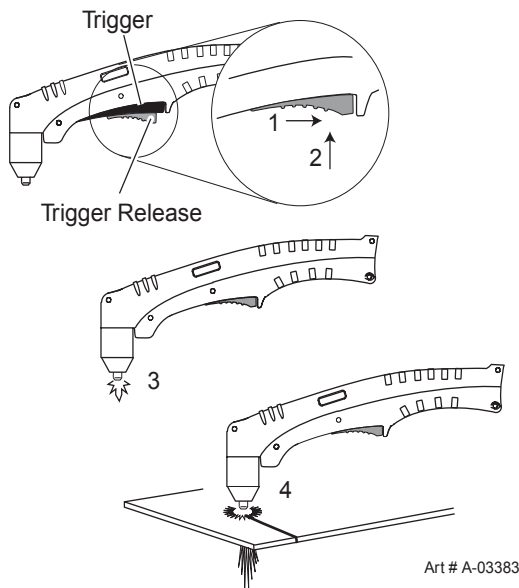

- Cut as usual. Simply release the trigger assembly to stop cutting.
- Follow normal recommended cutting practices as provided in the power supply operator's manual.



NOTE!

When the shield cup is properly installed, there is a slight gap between the shield cup and the torch handle. Gas vents through this gap as part of normal operation. Do not attempt to force the shield cup to close this gap. Forcing the shield cup against the torch head or torch handle can damage components.

- Angle the torch slightly to direct blowback particles away from the torch tip (and operator) rather than directly back into it until the pierce is complete.
- In a portion of the unwanted metal start the pierce off the cutting line and then continue the cut onto the line. Hold the torch perpendicular to the workpiece after the pierce is complete.
- Hold the torch away from your body.
- Slide the trigger release toward the back of the torch handle while simultaneously squeezing the trigger. The pilot arc will start.

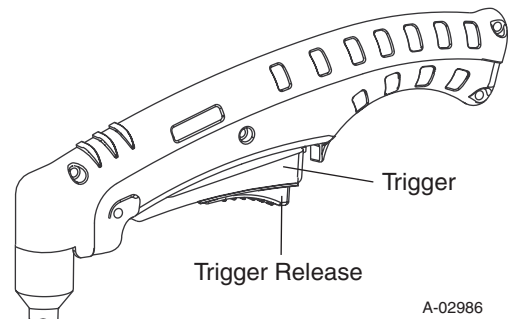

- Bring the torch within transfer distance to the work. The main arc will transfer to the work, and the pilot arc will shut off.

ESAB CUTMASTER 120



NOTE!

The gas preflow and postflow are a characteristic of the power supply and not a function of the torch. When the shield cup is properly installed, there is a slight gap between the shield cup and the torch handle. Gas vents through this gap as part of normal operation. Do not attempt to force the shield cup to close this gap. Forcing the shield cup against the torch head or torch handle can damage components.

7. Clean spatter and scale from the shield cup and the tip as soon as possible. Spraying the shield cup in anti - spatter compound will minimize the amount of scale which adheres to it.

Cutting speed depends on material, thickness, and the operator's ability to accurately follow the desired cut line. The following factors may have an impact on system performance:

- Torch parts wear
- Air quality
- Line voltage fluctuations
- Torch standoff height
- Proper work cable connection

4T.05 Gouging



WARNING

Be sure the operator is equipped with proper gloves, clothing, eye and ear protection and that all safety precautions at the front of this manual have been followed. Make sure no part of the operator's body comes in contact with the workpiece when the torch is activated.

Disconnect primary power to the system before disassembling the torch, leads, or power supply.



CAUTION

Sparks from plasma gouging can cause damage to coated, painted or other surfaces such as glass, plastic, and metal.

Check torch parts. The torch parts must correspond with the type of operation. Refer to Section 4T.07, Torch Parts Selection.

Gouging Parameters

Gouging performance depends on parameters such as torch travel speed, current level, lead angle (the angle between the torch and workpiece), and the distance between the torch tip and workpiece (standoff).



CAUTION

Touching the torch tip or shield cup to the work surface will cause excessive parts wear.

Torch Travel Speed



NOTE!

Refer to Appendix Pages for additional information as related to the Power Supply used.

Optimum torch travel speed is dependent on current setting, lead angle, and mode of operation (hand or machine torch).

Current Setting

Current settings depend on torch travel speed, mode of operation (hand or machine torch), and the amount of material to be removed.

Pressure Setting

Even though the setting is within the specified range, if the torch does not pilot well the pressure may need to be reduced.

Lead Angle

The angle between the torch and workpiece depends on the output current setting and torch travel speed. The recommended lead angle is 35°. At a lead angle greater than 45° the molten metal will not be blown out of the gouge and may be blown back onto the torch. If the lead angle is too small (less than 35°), less material may be removed, requiring more passes. In some applications, such as removing welds or working with light metal, this may be desirable.

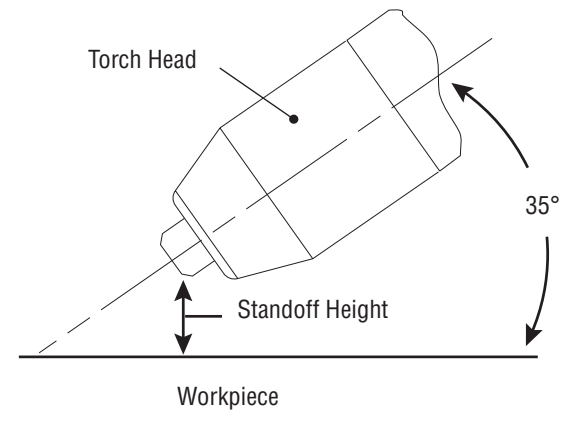

A-00941_AB

Gouging Angle and Standoff Distance

Standoff Distance

The tip to work distance affects gouge quality and depth. Standoff distance of 1/8 - 1/4 inch (3 - 6 mm) allows for smooth, consistent metal removal. Smaller standoff distances may result in a severance cut rather than a gouge. Standoff distances greater than 1/4 inch (6 mm) may result in minimal metal removal or loss of transferred main arc.

Slag Buildup

Slag generated by gouging on materials such as carbon and stainless steels, nickels, and alloyed steels, can be removed easily in most cases. Slag does not obstruct the gouging process if it accumulates to the side of the gouge path. However, slag build - up can cause inconsistencies and irregular metal removal if large amounts of material build up in front of the arc. The build - up is most often a result of improper travel speed, lead angle, or standoff height.

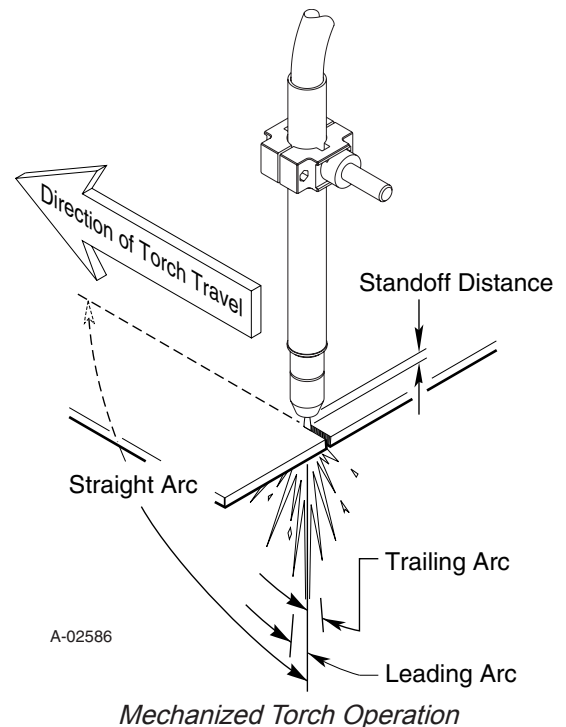

4T.06 Mechanized Torch Operation

Cutting With Mechanized Torch

The mechanized torch can be activated by remote control pendant or by a remote interface device such as CNC.

1. To start a cut at the plate edge, position the center of the torch along the edge of the plate.

Travel Speed

Proper travel speed is indicated by the trail of the arc which is seen below the plate. The arc can be one of the following:

1. Straight Arc

A straight arc is perpendicular to the workpiece surface. This arc is generally recommended for the best cut using air plasma on stainless or aluminum.
2. Leading Arc

The leading arc is directed in the same direction as torch travel. A five degree leading arc is generally recommended for air plasma on mild steel.
3. Trailing Arc

The trailing arc is directed in the opposite direction as torch travel.

For optimum smooth surface quality, the travel speed should be adjusted so that only the leading edge of the arc column produces the cut. If the travel speed is too slow, a rough cut will be produced as the arc moves from side to side in search of metal for transfer.

Travel speed also affects the bevel angle of a cut. When cutting in a circle or around a corner, slowing down the travel speed will result in a squarer cut. The power source output should be reduced also. Refer to the appropriate Control Module Operating Manual for any Corner Slowdown adjustments that may be required.

Piercing With Machine Torch

To pierce with a machine torch, the arc should be started with the torch positioned as high as possible above the plate while allowing the arc to transfer and pierce. This standoff helps avoid having molten metal blow back onto the front end of the torch.

When operating with a cutting machine, a pierce or dwell time is required. Torch travel should not be enabled until the arc penetrates the bottom of the plate. As motion begins, torch standoff should be reduced to the recommended 1/8 - 1/4 inch (3-6 mm) distance for optimum speed and cut quality. Clean spatter and scale from the shield cup and the tip as soon as possible. Spraying or dipping the shield cup in anti - spatter compound will minimize the amount of scale which adheres to it.

ESAB CUTMASTER 120

4T.07 Parts Selection for SL100 Torch Cutting

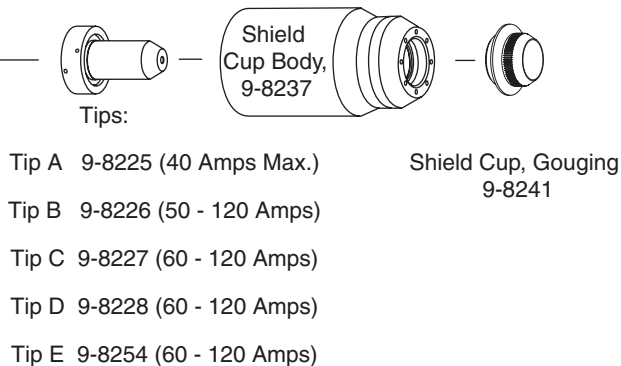
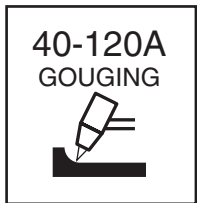
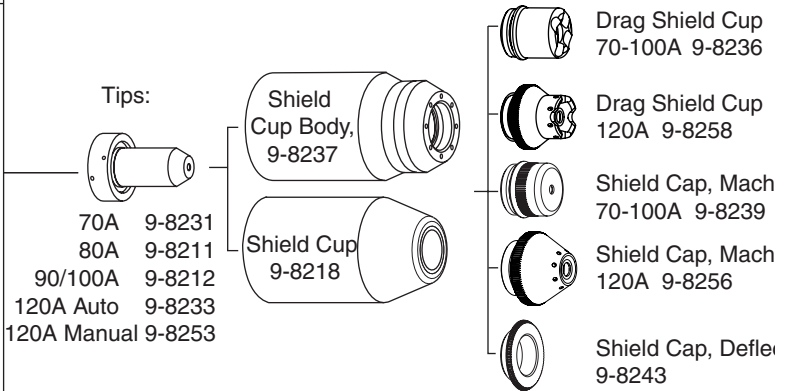
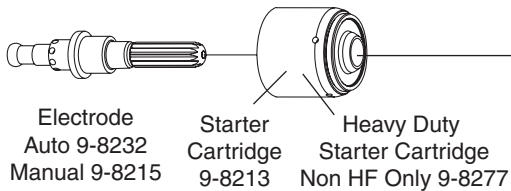
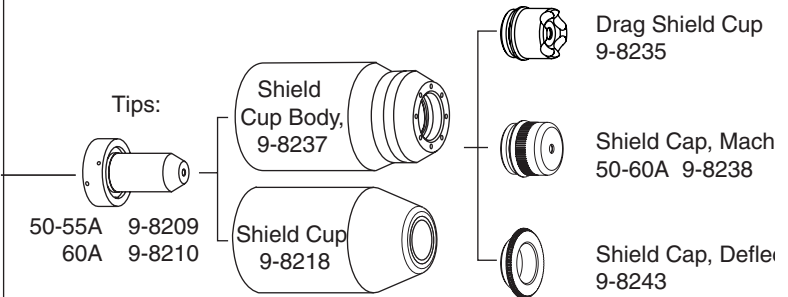
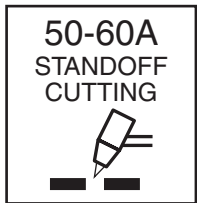
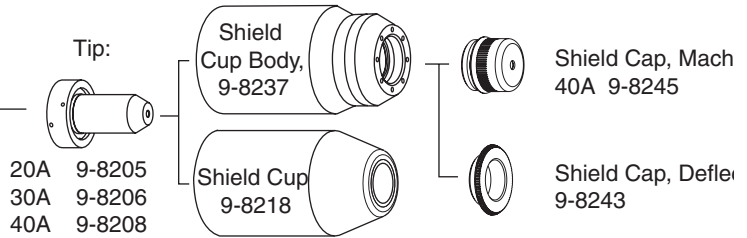
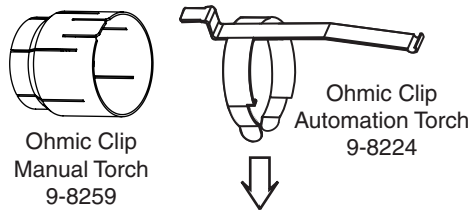

Art # A-08066_AG

4T.08 Recommended Cutting Speeds for SL100 Torch With Exposed Tip

Type Torch: SL100 With Exposed Tip							Type Material: Mild Steel								
Type Plasma Gas: Air							Type Secondary Gas: Single Gas Torch								
Thickness		Tip	Output	Amperage	Speed (Per Minute)		Standoff		Plasma Gas Press		Flow (CFH)		Pierce	Pierce Height	
Inches	mm	(Cat. No.)	Volts(VDC)	(Amps)	Inches	Meters	Inches	mm	psi*	bar	Plasma	Total**	Delay (Sec)	Inches	mm
0,036	0,9	9-8208	104	40	340	8,64	0,19	4,8	65	4,5	55	170	0,00	0,2	5,1
0,06	1,5	9-8208	108	40	250	6,35	0,19	4,8	65	4,5	55	170	0,10	0,2	5,1
0,075	1,9	9-8208	108	40	190	4,83	0,19	4,8	65	4,5	55	170	0,30	0,2	5,1
0,135	3,4	9-8208	110	40	105	2,67	0,19	4,8	65	4,5	55	170	0,40	0,2	5,1
0,188	4,8	9-8208	113	40	60	1,52	0,19	4,8	65	4,5	55	170	0,60	0,2	5,1
0,25	6,4	9-8208	111	40	40	1,02	0,19	4,8	65	4,5	55	170	1,00	0,2	5,1
0,375	9,5	9-8208	124	40	21	0,53	0,19	4,8	65	4,5	55	170	NR	NR	NR
0,500	12,7	9-8208	123	40	11	0,28	0,19	4,8	65	4,5	55	170	NR	NR	NR
0,625	15,9	9-8208	137	40	7	0,18	0,19	4,8	65	4,5	55	170	NR	NR	NR

Type Torch: SL100 With Exposed Tip							Type Material: Stainless Steel								
Type Plasma Gas: Air							Type Secondary Gas: Single Gas Torch								
Thickness		Tip	Output	Amperage	Speed (Per Minute)		Standoff		Plasma Gas Press		Flow (CFH)		Pierce	Pierce Height	
Inches	mm	(Cat. No.)	Volts(VDC)	(Amps)	Inches	Meters	Inches	mm	psi*	bar	Plasma	Total**	Delay (Sec)	Inches	mm
0,036	0,9	9-8208	103	40	355	9,02	0,125	3,2	65	4,5	55	170	0,00	0,2	5,1
0,05	1,3	9-8208	98	40	310	7,87	0,125	3,2	65	4,5	55	170	0,00	0,2	5,1
0,06	1,5	9-8208	98	40	240	6,10	0,125	3,2	65	4,5	55	170	0,10	0,2	5,1
0,078	2,0	9-8208	100	40	125	3,18	0,125	3,2	65	4,5	55	170	0,30	0,2	5,1
0,135	3,4	9-8208	120	40	30	0,76	0,187	4,8	65	4,5	55	170	0,40	0,2	5,1
0,188	4,8	9-8208	124	40	20	0,51	0,187	4,8	65	4,5	55	170	0,60	0,2	5,1
0,25	6,4	9-8208	122	40	15	0,38	0,187	4,8	65	4,5	55	170	1,00	0,2	5,1
0,375	9,5	9-8208	126	40	10	0,25	0,187	4,8	65	4,5	55	170	NR	NR	NR

Type Torch: SL100 With Exposed Tip							Type Material: Aluminum								
Type Plasma Gas: Air							Type Secondary Gas: Single Gas Torch								
Thickness		Tip	Output	Amperage	Speed (Per Minute)		Standoff		Plasma Gas Press		Flow (CFH)		Pierce	Pierce Height	
Inches	mm	(Cat. No.)	Volts(VDC)	(Amps)	Inches	Meters	Inches	mm	psi*	bar	Plasma	Total**	Delay (Sec)	Inches	mm
0,032	0,8	9-8208	110	40	440	11,18	0,187	4,8	65	4,5	55	170	0,00	0,2	5,1
0,051	1,3	9-8208	109	40	350	8,89	0,187	4,8	65	4,5	55	170	0,10	0,2	5,1
0,064	1,6	9-8208	112	40	250	6,35	0,187	4,8	65	4,5	55	170	0,10	0,2	5,1
0,079	2,0	9-8208	112	40	200	5,08	0,19	4,8	65	4,5	55	170	0,30	0,2	5,1
0,125	3,2	9-8208	118	40	100	2,54	0,19	4,8	65	4,5	55	170	0,40	0,2	5,1
0,188	4,8	9-8208	120	40	98	2,49	0,187	4,8	65	4,5	55	170	0,60	0,2	5,1
0,250	6,4	9-8208	123	40	50	1,27	0,187	4,8	65	4,5	55	170	1,00	0,2	5,1
0,375	9,5	9-8208	134	40	16	0,41	0,187	4,8	65	4,5	55	170	NR	NR	NR

ESAB CUTMASTER 120

Type Torch: SL100 With Exposed Tip							Type Material: Mild Steel								
Type Plasma Gas: Air							Type Secondary Gas: Single Gas Torch								
Thickness		Tip	Output	Amperage	Speed (Per Minute)		Standoff		Plasma Gas Press		Flow (CFH)		Pierce	Pierce Height	
Inches	mm	(Cat. No.)	Volts(VDC)	(Amps)	Inches	Meters	Inches	mm	psi*	bar	Plasma	Total**	Delay (Sec)	Inches	mm
0,060	1,5	9-8210	110	60	290	7,37	0,19	4,8	70	4,8	90	245	0,00	0,19	4,8
0,075	1,9	9-8210	120	60	285	7,24	0,19	4,8	70	4,8	90	245	0,10	0,19	4,8
0,120	3,0	9-8210	120	60	180	4,57	0,19	4,8	70	4,8	90	245	0,10	0,19	4,8
0,135	3,4	9-8210	119	60	170	4,32	0,19	4,8	70	4,8	90	245	0,10	0,19	4,8
0,188	4,8	9-8210	121	60	100	2,54	0,19	4,8	70	4,8	90	245	0,20	0,19	4,8
0,250	6,4	9-8210	119	60	80	2,03	0,19	4,8	70	4,8	90	245	0,30	0,19	4,8
0,375	9,5	9-8210	124	60	50	1,27	0,19	4,8	70	4,8	90	245	0,50	0,19	4,8
0,500	12,7	9-8210	126	60	26	0,66	0,19	4,8	70	4,8	90	245	0,75	0,19	4,8
0,625	15,9	9-8210	127	60	19	0,48	0,19	4,8	70	4,8	90	245	NR	NR	NR
0,750	19,1	9-8210	134	60	14	0,36	0,19	4,8	70	4,8	90	245	NR	NR	NR
1,000	25,4	9-8210	140	60	6	0,15	0,19	4,8	70	4,8	90	245	NR	NR	NR

Type Torch: SL100 With Exposed Tip							Type Material: Stainless Steel								
Type Plasma Gas: Air							Type Secondary Gas: Single Gas Torch								
Thickness		Tip	Output	Amperage	Speed (Per Minute)		Standoff		Plasma Gas Press		Flow (CFH)		Pierce	Pierce Height	
Inches	mm	(Cat. No.)	Volts(VDC)	(Amps)	Inches	Meters	Inches	mm	psi*	bar	Plasma	Total**	Delay (Sec)	Inches	mm
0,06	1,5	9-8210	119	60	350	8,91	0,19	4,8	70	4,8	90	245	0,00	0,20	5,1
0,075	1,9	9-8210	116	60	300	7,64	0,19	4,8	70	4,8	90	245	0,10	0,20	5,1
0,120	3,0	9-8210	123	60	150	3,82	0,19	4,8	70	4,8	90	245	0,10	0,20	5,1
0,135	3,4	9-8210	118	60	125	3,18	0,19	4,8	70	4,8	90	245	0,10	0,20	5,1
0,188	4,8	9-8210	122	60	90	2,29	0,19	4,8	70	4,8	90	245	0,20	0,20	5,1
0,250	6,4	9-8210	120	60	65	1,65	0,19	4,8	70	4,8	90	245	0,30	0,20	5,1
0,375	9,5	9-8210	130	60	30	0,76	0,19	4,8	70	4,8	90	245	0,50	0,20	5,1
0,500	12,7	9-8210	132	60	21	0,53	0,19	4,8	70	4,8	90	245	0,75	0,20	5,1
0,625	15,9	9-8210	130	60	15	0,38	0,19	4,8	70	4,8	90	245	NR	NR	NR
0,750	19,1	9-8210	142	60	12	0,31	0,25	6,4	70	4,8	90	245	NR	NR	NR

Type Torch: SL100 With Exposed Tip							Type Material: Aluminum								
Type Plasma Gas: Air							Type Secondary Gas: Single Gas Torch								
Thickness		Tip	Output	Amperage	Speed (Per Minute)		Standoff		Plasma Gas Press		Flow (CFH)		Pierce	Pierce Height	
Inches	mm	(Cat. No.)	Volts(VDC)	(Amps)	Inches	Meters	Inches	mm	psi*	bar	Plasma	Total**	Delay (Sec)	Inches	mm
0,060	1,5	9-8210	110	60	440	11,18	0,25	6,4	70	4,8	90	245	0,00	0,25	6,4
0,075	1,9	9-8210	110	60	440	11,18	0,25	6,4	70	4,8	90	245	0,10	0,25	6,4
0,120	3,0	9-8210	116	60	250	6,35	0,25	6,4	70	4,8	90	245	0,10	0,25	6,4
0,188	3,4	9-8210	116	60	170	4,32	0,25	6,4	70	4,8	90	245	0,20	0,25	6,4
0,250	6,4	9-8210	132	60	85	2,16	0,25	6,4	70	4,8	90	245	0,30	0,25	6,4
0,375	9,5	9-8210	140	60	45	1,14	0,25	6,4	70	4,8	90	245	0,50	0,25	6,4
0,500	12,7	9-8210	143	60	30	0,76	0,25	6,4	70	4,8	90	245	0,80	0,25	6,4
0,625	15,9	9-8210	145	60	20	0,51	0,25	6,4	70	4,8	90	245	NR	NR	NR
0,750	19,1	9-8210	145	60	18	0,46	0,25	6,4	70	4,8	90	245	NR	NR	NR

ESAB CUTMASTER 120

Type Torch: SL100 With Exposed Tip							Type Material: Mild Steel								
Type Plasma Gas: Air							Type Secondary Gas: Single Gas Torch								
Thickness		Tip	Output	Amperage	Speed (Per Minute)		Standoff		Plasma Gas Press		Flow (CFH)		Pierce	Pierce Height	
Inches	mm	(Cat. No.)	Volts(VDC)	(Amps)	Inches	Meters	Inches	mm	psi*	bar	Plasma	Total**	Delay (Sec)	Inches	mm
0,060	1,5	9-8211	113	80	320	8,13	0,19	4,8	65	4,5	115	340	0,00	0,19	4,8
0,120	3,0	9-8211	113	80	230	5,84	0,19	4,8	65	4,5	115	340	0,10	0,19	4,8
0,135	3,4	9-8211	115	80	180	4,57	0,19	4,8	65	4,5	115	340	0,10	0,19	4,8
0,188	4,8	9-8211	114	80	140	3,56	0,19	4,8	65	4,5	115	340	0,20	0,19	4,8
0,250	6,4	9-8211	114	80	100	2,54	0,19	4,8	65	4,5	115	340	0,30	0,19	4,8
0,375	9,5	9-8211	117	80	42	1,07	0,19	4,8	65	4,5	115	340	0,40	0,19	4,8
0,500	12,7	9-8211	120	80	33	0,84	0,19	4,8	65	4,5	115	340	0,60	0,19	4,8
0,625	15,9	9-8211	133	80	22	0,56	0,19	4,8	65	4,5	115	340	0,75	0,19	4,8
0,750	19,1	9-8211	128	80	18	0,46	0,19	4,8	65	4,5	115	340	NR	NR	NR
0,875	22,2	9-8211	133	80	10	0,25	0,19	4,8	65	4,5	115	340	NR	NR	NR
1,000	25,4	9-8211	132	80	9	0,23	0,19	4,8	65	4,5	115	340	NR	NR	NR

Type Torch: SL100 With Exposed Tip							Type Material: Stainless Steel								
Type Plasma Gas: Air							Type Secondary Gas: Single Gas Torch								
Thickness		Tip	Output	Amperage	Speed (Per Minute)		Standoff		Plasma Gas Press		Flow (CFH)		Pierce	Pierce Height	
Inches	mm	(Cat. No.)	Volts(VDC)	(Amps)	Inches	Meters	Inches	mm	psi*	bar	Plasma	Total**	Delay (Sec)	Inches	mm
0,060	1,5	9-8211	120	80	340	8,64	0,25	6,4	65	4,5	115	340	0,00	0,25	6,4
0,120	3,0	9-8211	120	80	300	7,62	0,25	6,4	65	4,5	115	340	0,10	0,25	6,4
0,135	3,4	9-8211	120	80	280	7,11	0,25	6,4	65	4,5	115	340	0,10	0,25	6,4
0,188	4,8	9-8211	120	80	140	3,56	0,25	6,4	65	4,5	115	340	0,20	0,25	6,4
0,250	6,4	9-8211	120	80	100	2,54	0,25	6,4	65	4,5	115	340	0,30	0,25	6,4
0,375	9,5	9-8211	126	80	50	1,27	0,25	6,4	65	4,5	115	340	0,40	0,25	6,4
0,500	12,7	9-8211	129	80	28	0,71	0,25	6,4	65	4,5	115	340	0,80	0,25	6,4
0,625	15,9	9-8211	135	80	20	0,51	0,25	6,4	65	4,5	115	340	1,00	0,25	6,4
0,750	19,1	9-8211	143	80	10	0,25	0,25	6,4	65	4,5	115	340	NR	NR	NR
0,875	22,2	9-8211	143	80	9	0,23	0,25	6,4	65	4,5	115	340	NR	NR	NR
1,000	25,4	9-8211	146	80	8	0,20	0,25	6,4	65	4,5	115	340	NR	NR	NR

Type Torch: SL100 with Exposed Tip							Type Material: Aluminum								
Type Plasma Gas: Air							Type Secondary Gas: Single Gas Torch								
Thickness		Tip	Output	Amperage	Speed (Per Minute)		Standoff		Plasma Gas Press		Flow (CFH)		Pierce	Pierce Height	
Inches	mm	(Cat. No.)	Volts(VDC)	(Amps)	Inches	Meters	Inches	mm	psi*	bar	Plasma	Total**	Delay (Sec)	Inches	mm
0,06	1,5	9-8211	120	80	350	8,89	0,25	6,4	65	4,5	115	340	0,00	0,25	6,4
0,12	3,0	9-8211	124	80	300	7,62	0,25	6,4	65	4,5	115	340	0,10	0,25	6,4
0,188	4,8	9-8211	124	80	180	4,57	0,25	6,4	65	4,5	115	340	0,20	0,25	6,4
0,250	6,4	9-8211	128	80	110	2,79	0,25	6,4	65	4,5	115	340	0,30	0,25	6,4
0,375	9,5	9-8211	136	80	55	1,40	0,25	6,4	65	4,5	115	340	0,40	0,25	6,4
0,500	12,7	9-8211	139	80	38	0,97	0,25	6,4	65	4,5	115	340	0,60	0,25	6,4
0,625	15,9	9-8211	142	80	26	0,66	0,25	6,4	65	4,5	115	340	0,75	0,25	6,4
0,750	19,1	9-8211	145	80	24	0,61	0,25	6,4	65	4,5	115	340	NR	NR	NR
0,875	22,2	9-8211	153	80	10	0,25	0,25	6,4	65	4,5	115	340	NR	NR	NR
1,000	25,4	9-8211	162	80	6	0,15	0,25	6,4	65	4,5	115	340	NR	NR	NR

ESAB CUTMASTER 120

Type Torch: SL100 With Exposed Tip							Type Material: Mild Steel								
Type Plasma Gas: Air							Type Secondary Gas: Single Gas Torch								
Thickness		Tip	Output	Amperage	Speed (Per Minute)		Standoff		Plasma Gas Press		Flow (CFH)		Pierce	Pierce Height	
Inches	mm	(Cat. No.)	Volts(VDC)	(Amps)	Inches	Meters	Inches	mm	psi*	bar	Plasma	Total**	Delay (Sec)	Inches	mm
0,250	6,4	9-8212	110	100	105	2,65	0,190	4,8	75	5,2	130	390	0,4	0,200	5,1
0,375	9,5	9-8212	117	100	70	1,75	0,190	4,8	75	5,2	130	390	0,5	0,200	5,1
0,500	12,7	9-8212	120	100	50	1,25	0,190	4,8	75	5,2	130	390	0,6	0,200	5,1
0,625	15,9	9-8212	125	100	35	0,90	0,190	4,8	75	5,2	130	390	1,0	0,200	5,1
0,750	19,0	9-8212	131	100	18	0,45	0,190	4,8	75	5,2	130	390	2,0	0,250	6,4
1,000	25,4	9-8212	135	100	10	0,25	0,190	4,8	75	5,2	130	390	NR	NR	NR

Type Torch: SL100 With Exposed Tip							Type Material: Stainless Steel								
Type Plasma Gas: Air							Type Secondary Gas: Single Gas Torch								
Thickness		Tip	Output	Amperage	Speed (Per Minute)		Standoff		Plasma Gas Press		Flow (CFH)		Pierce	Pierce Height	
Inches	mm	(Cat. No.)	Volts(VDC)	(Amps)	Inches	Meters	Inches	mm	psi*	bar	Plasma	Total**	Delay (Sec)	Inches	mm
0,250	6,4	9-8212	118	100	90	2,30	0,190	4,8	75	5,2	130	390	0,5	0,250	6,4
0,375	9,5	9-8212	122	100	55	1,40	0,190	4,8	75	5,2	130	390	0,8	0,250	6,4
0,500	12,7	9-8212	126	100	30	0,75	0,190	4,8	75	5,2	130	390	1,0	0,250	6,4
0,625	15,9	9-8212	133	100	20	0,50	0,190	4,8	75	5,2	130	390	1,5	0,250	6,4
0,750	19,0	9-8212	138	100	15	0,40	0,190	4,8	75	5,2	130	390	NR	NR	NR
1,000	25,4	9-8212	139	100	10	0,25	0,190	4,8	75	5,2	130	390	NR	NR	NR

Type Torch: SL100 with Exposed Tip							Type Material: Aluminum								
Type Plasma Gas: Air							Type Secondary Gas: Single Gas Torch								
Thickness		Tip	Output	Amperage	Speed (Per Minute)		Standoff		Plasma Gas Press		Flow (CFH)		Pierce	Pierce Height	
Inches	mm	(Cat. No.)	Volts(VDC)	(Amps)	Inches	Meters	Inches	mm	psi*	bar	Plasma	Total**	Delay (Sec)	Inches	mm
0,250	6,4	9-8212	108	100	120	3,05	0,190	4,8	65	4,5	120	360	0,2	0,225	5,7
0,375	9,5	9-8212	117	100	65	1,65	0,190	4,8	65	4,5	120	360	0,4	0,225	5,7
0,500	12,7	9-8212	120	100	45	1,15	0,190	4,8	65	4,5	120	360	0,5	0,225	5,7
0,625	15,9	9-8212	125	100	30	0,75	0,190	4,8	65	4,5	120	360	0,8	0,225	5,7
0,750	19,0	9-8212	131	100	25	0,65	0,190	4,8	65	4,5	120	360	1,0	0,225	5,7
1,000	25,4	9-8212	140	100	10	0,25	0,190	4,8	65	4,5	120	360	NR	NR	NR

Type Torch: SL100 With Exposed Tip							Type Material: Mild Steel								
Type Plasma Gas: Air							Type Secondary Gas: Single Gas Torch								
Thickness		Tip	Output	Amperage	Speed (Per Minute)		Standoff		Plasma Gas Press		Flow (CFH)		Pierce	Pierce Height	
Inches	mm	(Cat. No.)	Volts(VDC)	(Amps)	Inches	Meters	Inches	mm	psi*	bar	Plasma	Total**	Delay (Sec)	Inches	mm
0,250	6,4	9-8253	138	120	150	3,81	0,19	4,8	75	5,2	180	360	0,10	0,25	6,4
0,375	9,5	9-8253	140	120	85	2,16	0,19	4,8	75	5,2	180	360	0,30	0,25	6,4
0,500	12,7	9-8253	144	120	70	1,78	0,19	4,8	75	5,2	180	360	0,50	0,25	6,4
0,625	15,9	9-8253	152	120	45	1,14	0,19	4,8	75	5,2	180	360	0,70	0,25	6,4
0,750	19,0	9-8253	155	120	30	0,76	0,19	4,8	75	5,2	180	360	0,90	0,25	6,4
0,875	22,2	9-8253	160	120	25	0,64	0,25	6,4	75	5,2	180	360	NR	NR	NR
1,000	25,4	9-8253	164	120	20	0,51	0,25	6,4	75	5,2	180	360	NR	NR	NR
1,250	31,8	9-8253	170	120	12	0,30	0,25	6,4	75	5,2	180	360	NR	NR	NR
1,500	38,1	9-8253	180	120	8	0,20	0,25	6,4	75	5,2	180	360	NR	NR	NR

ESAB CUTMASTER 120

Type Torch: SL100 With Exposed Tip							Type Material: Stainless Steel								
Type Plasma Gas: Air							Type Secondary Gas: Single Gas Torch								
Thickness		Tip	Output	Amperage	Speed (Per Minute)		Standoff		Plasma Gas Press		Flow (CFH)		Pierce	Pierce Height	
Inches	mm	(Cat. No.)	Volts(VDC)	(Amps)	Inches	Meters	Inches	mm	psi*	bar	Plasma	Total**	Delay (Sec)	Inches	mm
0,250	6,4	9-8253	135	120	180	4,57	0,19	4,8	75	5,2	180	360	0,20	0,25	6,4
0,375	9,5	9-8253	144	120	100	2,54	0,19	4,8	75	5,2	180	360	0,40	0,25	6,4
0,500	12,7	9-8253	146	120	60	1,52	0,19	4,8	75	5,2	180	360	0,80	0,25	6,4
0,625	15,9	9-8253	155	120	40	1,02	0,25	6,4	75	5,2	180	360	1,20	0,28	7,0
0,750	19,0	9-8253	164	120	26	0,66	0,25	6,4	75	5,2	180	360	NR	NR	NR
1,000	25,4	9-8253	164	120	18	0,46	0,25	6,4	75	5,2	180	360	NR	NR	NR
1,250	31,8	9-8253	170	120	9	0,23	0,25	6,4	75	5,2	180	360	NR	NR	NR

Type Torch: SL100 with Exposed Tip							Type Material: Aluminum								
Type Plasma Gas: Air							Type Secondary Gas: Single Gas Torch								
Thickness		Tip	Output	Amperage	Speed (Per Minute)		Standoff		Plasma Gas Press		Flow (CFH)		Pierce	Pierce Height	
Inches	mm	(Cat. No.)	Volts(VDC)	(Amps)	Inches	Meters	Inches	mm	psi*	bar	Plasma	Total**	Delay (Sec)	Inches	mm
0,250	6,4	9-8253	142	120	190	4,83	0,19	4,8	75	5,2	180	360	0,30	0,25	6,4
0,375	9,5	9-8253	145	120	120	3,05	0,19	4,8	75	5,2	180	360	0,50	0,25	6,4
0,500	12,7	9-8253	151	120	70	1,78	0,19	4,8	75	5,2	180	360	0,80	0,25	6,4
0,625	15,9	9-8253	162	120	50	1,27	0,25	6,4	75	5,2	180	360	1,00	0,28	7,0
0,750	19,0	9-8253	164	120	34	0,86	0,25	6,4	75	5,2	180	360	NR	NR	NR
1,000	25,4	9-8253	170	120	20	0,51	0,25	6,4	75	5,2	180	360	NR	NR	NR



NOTE!

* Gas pressure shown is for torches with leads up to 25' / 7.6 m long. For 50' / 15.2 m leads, refer to Section "Set Operating Pressure" on page <?>.

** Total flow rate includes plasma and secondary gas flow.

ESAB CUTMASTER 120

4T.09 Recommended Cutting Speeds for SL100 Torch With Shielded Tip

Type Torch: SL100 With Shielded Tip							Type Material: Mild Steel								
Type Plasma Gas: Air							Type Secondary Gas: Single Gas Torch								
Thickness		Tip	Output	Amperage	Speed (Per Minute)		Standoff		Plasma Gas Press		Flow (CFH)		Pierce	Pierce Height	
Inches	mm	(Cat. No.)	Volts (VDC)	(Amps)	Inches	Meters	Inches	mm	psi*	bar	Plasma	Total**	Delay (Sec)	Inches	mm
0,036	0,9	9-8208	114	40	170	4,32	0,19	4,8	65	4,5	55	170	0,00	0,2	5,1
0,06	1,5	9-8208	120	40	90	2,29	0,19	4,8	65	4,5	55	170	0,10	0,2	5,1
0,075	1,9	9-8208	121	40	80	2,03	0,19	4,8	65	4,5	55	170	0,30	0,2	5,1
0,135	3,4	9-8208	122	40	75	1,91	0,19	4,8	65	4,5	55	170	0,40	0,2	5,1
0,188	4,8	9-8208	123	40	30	0,76	0,19	4,8	65	4,5	55	170	0,60	0,2	5,1
0,25	6,4	9-8208	125	40	25	0,64	0,19	4,8	65	4,5	55	170	1,00	0,2	5,1
0,375	9,5	9-8208	138	40	11	0,28	0,19	4,8	65	4,5	55	170	NR	NR	NR
0,500	12,7	9-8208	142	40	7	0,18	0,19	4,8	65	4,5	55	170	NR	NR	NR
0,625	15,9	9-8208	152	40	3	0,08	0,19	4,8	65	4,5	55	170	NR	NR	NR

Type Torch: SL100 With Shielded Tip							Type Material: Stainless Steel								
Type Plasma Gas: Air							Type Secondary Gas: Single Gas Torch								
Thickness		Tip	Output	Amperage	Speed (Per Minute)		Standoff		Plasma Gas Press		Flow (CFH)		Pierce	Pierce Height	
Inches	mm	(Cat. No.)	Volts(VDC)	(Amps)	Inches	Meters	Inches	mm	psi*	bar	Plasma	Total**	Delay (Sec)	Inches	mm
0,036	0,9	9-8208	109	40	180	4,57	0,125	3,2	65	4,5	55	170	0,00	0,2	5,1
0,05	1,3	9-8208	105	40	165	4,19	0,125	3,2	65	4,5	55	170	0,00	0,2	5,1
0,06	1,5	9-8208	115	40	120	3,05	0,125	3,2	65	4,5	55	170	0,10	0,2	5,1
0,078	2,0	9-8208	120	40	65	1,65	0,187	4,8	65	4,5	55	170	0,30	0,2	5,1
0,135	3,4	9-8208	125	40	25	0,64	0,187	4,8	65	4,5	55	170	0,40	0,2	5,1
0,188	4,8	9-8208	132	40	20	0,51	0,187	4,8	65	4,5	55	170	0,60	0,2	5,1
0,25	6,4	9-8208	130	40	15	0,38	0,187	4,8	65	4,5	55	170	1,00	0,2	5,1
0,375	9,5	9-8208	130	40	10	0,25	0,187	4,8	65	4,5	55	170	NR	NR	NR

Type Torch: SL100 With Shielded Tip							Type Material: Aluminum								
Type Plasma Gas: Air							Type Secondary Gas: Single Gas Torch								
Thickness		Tip	Output	Amperage	Speed (Per Minute)		Standoff		Plasma Gas Press		Flow (CFH)		Pierce	Pierce Height	
Inches	mm	(Cat. No.)	Volts(VDC)	(Amps)	Inches	Meters	Inches	mm	psi*	bar	Plasma	Total**	Delay (Sec)	Inches	mm
0,032	0,8	9-8208	116	40	220	5,59	0,187	4,8	65	4,5	55	170	0,00	0,2	5,1
0,051	1,3	9-8208	116	40	210	5,33	0,187	4,8	65	4,5	55	170	0,00	0,2	5,1
0,064	1,6	9-8208	118	40	180	4,57	0,187	4,8	65	4,5	55	170	0,10	0,2	5,1
0,079	2,0	9-8208	116	40	150	3,81	0,19	4,8	65	4,5	55	170	0,30	0,2	5,1
0,125	3,2	9-8208	130	40	75	1,91	0,19	4,8	65	4,5	55	170	0,40	0,2	5,1
0,188	4,8	9-8208	132	40	60	1,52	0,187	4,8	65	4,5	55	170	0,60	0,2	5,1
0,250	6,4	9-8208	134	40	28	0,71	0,187	4,8	65	4,5	55	170	1,00	0,2	5,1
0,375	9,5	9-8208	143	40	11	0,28	0,187	4,8	65	4,5	55	170	NR	NR	NR

ESAB CUTMASTER 120

Type Torch: SL100 With Shielded Tip							Type Material: Mild Steel								
Type Plasma Gas: Air							Type Secondary Gas: Single Gas Torch								
Thickness		Tip	Output	Amperage	Speed (Per Minute)		Standoff		Plasma Gas Press		Flow (CFH)		Pierce	Pierce Height	
Inches	mm	(Cat. No.)	Volts(VDC)	(Amps)	Inches	Meters	Inches	mm	psi*	bar	Plasma	Total**	Delay (Sec)	Inches	mm
0,060	1,5	9-8210	124	60	250	6,35	0,19	4,8	70	4,8	90	245	0,00	0,2	5,1
0,075	1,9	9-8210	126	60	237	6,02	0,19	4,8	70	4,8	90	245	0,10	0,2	5,1
0,120	3,0	9-8210	126	60	230	5,84	0,19	4,8	70	4,8	90	245	0,10	0,2	5,1
0,135	3,4	9-8210	128	60	142	3,61	0,19	4,8	70	4,8	90	245	0,10	0,2	5,1
0,188	4,8	9-8210	128	60	125	3,18	0,19	4,8	70	4,8	90	245	0,20	0,2	5,1
0,250	6,4	9-8210	123	60	80	2,03	0,19	4,8	70	4,8	90	245	0,30	0,2	5,1
0,375	9,5	9-8210	132	60	34	0,86	0,19	4,8	70	4,8	90	245	0,50	0,2	5,1
0,500	12,7	9-8210	137	60	23	0,58	0,19	4,8	70	4,8	90	245	0,75	0,2	5,1
0,625	15,9	9-8210	139	60	14	0,36	0,19	4,8	70	4,8	90	245	NR	NR	NR
0,750	19,1	9-8210	145	60	14	0,36	0,19	4,8	70	4,8	90	245	NR	NR	NR
1,000	25,4	9-8210	156	60	4	0,10	0,19	4,8	70	4,8	90	245	NR	NR	NR

Type Torch: SL100 With Shielded Tip							Type Material: Stainless Steel								
Type Plasma Gas: Air							Type Secondary Gas: Single Gas Torch								
Thickness		Tip	Output	Amperage	Speed (Per Minute)		Standoff		Plasma Gas Press		Flow (CFH)		Pierce	Pierce Height	
Inches	mm	(Cat. No.)	Volts(VDC)	(Amps)	Inches	Meters	Inches	mm	psi*	bar	Plasma	Total**	Delay (Sec)	Inches	mm
0,06	1,5	9-8210	110	60	165	4,19	0,13	3,2	70	4,8	90	245	0,00	0,20	5,1
0,075	1,9	9-8210	116	60	155	3,94	0,13	3,2	70	4,8	90	245	0,10	0,20	5,1
0,120	3,0	9-8210	115	60	125	3,18	0,13	3,2	70	4,8	90	245	0,10	0,20	5,1
0,135	3,4	9-8210	118	60	80	2,03	0,13	3,2	70	4,8	90	245	0,10	0,20	5,1
0,188	4,8	9-8210	120	60	75	1,91	0,13	3,2	70	4,8	90	245	0,20	0,20	5,1
0,250	6,4	9-8210	121	60	60	1,52	0,13	3,2	70	4,8	90	245	0,30	0,20	5,1
0,375	9,5	9-8210	129	60	28	0,71	0,13	3,2	70	4,8	90	245	0,50	0,20	5,1
0,500	12,7	9-8210	135	60	17	0,43	0,19	4,8	70	4,8	90	245	0,75	0,20	5,1
0,625	15,9	9-8210	135	60	14	0,36	0,19	4,8	70	4,8	90	245	NR	NR	NR
0,750	19,1	9-8210	142	60	10	0,25	0,19	4,8	70	4,8	90	245	NR	NR	NR

Type Torch: SL100 With Shielded Tip							Type Material: Aluminum								
Type Plasma Gas: Air							Type Secondary Gas: Single Gas Torch								
Thickness		Tip	Output	Amperage	Speed (Per Minute)		Standoff		Plasma Gas Press		Flow (CFH)		Pierce	Pierce Height	
Inches	mm	(Cat. No.)	Volts(VDC)	(Amps)	Inches	Meters	Inches	mm	psi*	bar	Plasma	Total**	Delay (Sec)	Inches	mm
0,060	1,5	9-8210	105	60	350	8,89	0,13	3,2	70	4,8	90	245	0,00	0,20	5,1
0,075	1,9	9-8210	110	60	350	8,89	0,13	3,2	70	4,8	90	245	0,10	0,20	5,1
0,120	3,0	9-8210	110	60	275	6,99	0,13	3,2	70	4,8	90	245	0,10	0,20	5,1
0,188	3,4	9-8210	122	60	140	3,56	0,13	3,2	70	4,8	90	245	0,20	0,20	5,1
0,250	6,4	9-8210	134	60	80	2,03	0,19	4,8	70	4,8	90	245	0,30	0,20	5,1
0,375	9,5	9-8210	140	60	45	1,14	0,19	4,8	70	4,8	90	245	0,50	0,20	5,1
0,500	12,7	9-8210	144	60	26	0,66	0,19	4,8	70	4,8	90	245	0,80	0,20	5,1
0,625	15,9	9-8210	145	60	19	0,48	0,19	4,8	70	4,8	90	245	NR	NR	NR
0,750	19,1	9-8210	150	60	15	0,38	0,19	4,8	70	4,8	90	245	NR	NR	NR

ESAB CUTMASTER 120

Type Torch: SL100 With Shielded Tip							Type Material: Mild Steel								
Type Plasma Gas: Air							Type Secondary Gas: Single Gas Torch								
Thickness		Tip	Output	Amperage	Speed (Per Minute)		Standoff		Plasma Gas Press		Flow (CFH)		Pierce	Pierce Height	
Inches	mm	(Cat. No.)	Volts(VDC)	(Amps)	Inches	Meters	Inches	mm	psi*	bar	Plasma	Total**	Delay (Sec)	Inches	mm
0,060	1,5	9-8211	128	80	280	7,11	0,19	4,8	65	4,5	115	340	0,00	0,2	5,1
0,120	3,0	9-8211	126	80	203	5,16	0,19	4,8	65	4,5	115	340	0,10	0,2	5,1
0,135	3,4	9-8211	128	80	182	4,62	0,19	4,8	65	4,5	115	340	0,10	0,2	5,1
0,188	4,8	9-8211	128	80	137	3,48	0,19	4,8	65	4,5	115	340	0,20	0,2	5,1
0,250	6,4	9-8211	131	80	100	2,54	0,19	4,8	65	4,5	115	340	0,30	0,2	5,1
0,375	9,5	9-8211	134	80	40	1,02	0,19	4,8	65	4,5	115	340	0,50	0,2	5,1
0,500	12,7	9-8211	136	80	36	0,91	0,19	4,8	65	4,5	115	340	0,60	0,2	5,1
0,625	15,9	9-8211	145	80	21	0,53	0,19	4,8	65	4,5	115	340	0,75	0,2	5,1
0,750	19,1	9-8211	144	80	14	0,36	0,19	4,8	65	4,5	115	340	NR	NR	NR
0,875	22,2	9-8211	149	80	11	0,28	0,19	4,8	65	4,5	115	340	NR	NR	NR
1,000	25,4	9-8211	162	80	8	0,20	0,19	4,8	65	4,5	115	340	NR	NR	NR

Type Torch: SL100 With Shielded Tip							Type Material: Stainless Steel								
Type Plasma Gas: Air							Type Secondary Gas: Single Gas Torch								
Thickness		Tip	Output	Amperage	Speed (Per Minute)		Standoff		Plasma Gas Press		Flow (CFH)		Pierce	Pierce Height	
Inches	mm	(Cat. No.)	Volts(VDC)	(Amps)	Inches	Meters	Inches	mm	psi*	bar	Plasma	Total**	Delay (Sec)	Inches	mm
0,060	1,5	9-8211	110	80	340	8,50	0,125	3,2	65	4,5	115	340	0,00	0,2	5,1
0,120	3,0	9-8211	115	80	260	6,50	0,125	3,2	65	4,5	115	340	0,10	0,2	5,1
0,135	3,4	9-8211	113	80	250	6,25	0,125	3,2	65	4,5	115	340	0,10	0,2	5,1
0,188	4,8	9-8211	114	80	170	4,25	0,125	3,2	65	4,5	115	340	0,20	0,2	5,1
0,250	6,4	9-8211	116	80	85	2,13	0,125	3,2	65	4,5	115	340	0,30	0,2	5,1
0,375	9,5	9-8211	123	80	45	1,13	0,125	3,2	65	4,5	115	340	0,40	0,25	6,4
0,500	12,7	9-8211	133	80	18	0,45	0,125	3,2	65	4,5	115	340	0,75	0,25	6,4
0,625	15,9	9-8211	135	80	16	0,40	0,125	3,2	65	4,5	115	340	1,00	0,25	6,4
0,750	19,1	9-8211	144	80	8	0,20	0,125	3,2	65	4,5	115	340	NR	NR	NR
0,875	22,2	9-8211	137	80	8	0,20	0,125	3,2	65	4,5	115	340	NR	NR	NR
1,000	25,4	9-8211	140	80	8	0,20	0,125	3,2	65	4,5	115	340	NR	NR	NR

Type Torch: SL100 With Shielded Tip							Type Material: Aluminum								
Type Plasma Gas: Air							Type Secondary Gas: Single Gas Torch								
Thickness		Tip	Output	Amperage	Speed (Per Minute)		Standoff		Plasma Gas Press		Flow (CFH)		Pierce	Pierce Height	
Inches	mm	(Cat. No.)	Volts(VDC)	(Amps)	Inches	Meters	Inches	mm	psi*	bar	Plasma	Total**	Delay (Sec)	Inches	mm
0,06	1,5	9-8211	115	80	320	8,13	0,13	3,2	65	4,5	115	340	0,00	0,25	6,4
0,12	3,0	9-8211	120	80	240	6,10	0,13	3,2	65	4,5	115	340	0,10	0,25	6,4
0,188	4,8	9-8211	120	80	165	4,19	0,13	3,2	65	4,5	115	340	0,20	0,25	6,4
0,250	6,4	9-8211	124	80	100	2,54	0,13	3,2	65	4,5	115	340	0,30	0,25	6,4
0,375	9,5	9-8211	138	80	60	1,52	0,19	4,8	65	4,5	115	340	0,40	0,25	6,4
0,500	12,7	9-8211	141	80	36	0,91	0,19	4,8	65	4,5	115	340	0,60	0,25	6,4
0,625	15,9	9-8211	142	80	26	0,66	0,19	4,8	65	4,5	115	340	0,75	0,25	6,4
0,750	19,1	9-8211	150	80	18	0,46	0,19	4,8	65	4,5	115	340	NR	NR	NR
0,875	22,2	9-8211	156	80	8	0,20	0,19	4,8	65	4,5	115	340	NR	NR	NR
1,000	25,4	9-8211	164	80	6	0,15	0,19	4,8	65	4,5	115	340	NR	NR	NR

ESAB CUTMASTER 120

Type Torch: SL100 With Shielded Tip							Type Material: Mild Steel								
Type Plasma Gas: Air							Type Secondary Gas: Single Gas Torch								
Thickness		Tip	Output	Amperage	Speed (Per Minute)		Standoff		Plasma Gas Press		Flow (CFH)		Pierce	Pierce Height	
Inches	mm	(Cat. No.)	Volts(VDC)	(Amps)	Inches	Meters	Inches	mm	psi*	bar	Plasma	Total**	Delay (Sec)	Inches	mm
0,250	6,4	9-8212	124	100	110	2,80	0,180	4,6	75	5,2	130	390	0,4	0,200	5,1
0,375	9,5	9-8212	127	100	75	1,90	0,180	4,6	75	5,2	130	390	0,5	0,200	5,1
0,500	12,7	9-8212	132	100	50	1,30	0,180	4,6	75	5,2	130	390	0,6	0,200	5,1
0,625	15,9	9-8212	136	100	30	0,75	0,180	4,6	75	5,2	130	390	0,8	0,200	5,1
0,750	19,0	9-8212	140	100	18	0,45	0,190	4,8	75	5,2	130	390	2,0	0,225	5,7
1,000	25,4	9-8212	147	100	10	0,25	0,190	4,8	75	5,2	130	390	NR	NR	NR

Type Torch: SL100 With Shielded Tip							Type Material: Stainless Steel								
Type Plasma Gas: Air							Type Secondary Gas: Single Gas Torch								
Thickness		Tip	Output	Amperage	Speed (Per Minute)		Standoff		Plasma Gas Press		Flow (CFH)		Pierce	Pierce Height	
Inches	mm	(Cat. No.)	Volts(VDC)	(Amps)	Inches	Meters	Inches	mm	psi*	bar	Plasma	Total**	Delay (Sec)	Inches	mm
0,250	6,4	9-8212	121	100	110	2,80	0,125	3,2	75	5,2	130	390	0,5	0,200	5,1
0,375	9,5	9-8212	125	100	60	1,50	0,150	3,8	75	5,2	130	390	0,8	0,200	5,1
0,500	12,7	9-8212	132	100	35	0,90	0,150	3,8	75	5,2	130	390	1,0	0,200	5,1
0,625	15,9	9-8212	137	100	20	0,50	0,150	3,8	75	5,2	130	390	2,0	0,225	5,7
0,750	19,0	9-8212	144	100	15	0,40	0,190	4,8	75	5,2	130	390	NR	NR	NR
1,000	25,4	9-8212	154	100	8	0,20	0,190	4,8	75	5,2	130	390	NR	NR	NR

Type Torch: SL100 With Shielded Tip							Type Material: Aluminum								
Type Plasma Gas: Air							Type Secondary Gas: Single Gas Torch								
Thickness		Tip	Output	Amperage	Speed (Per Minute)		Standoff		Plasma Gas Press		Flow (CFH)		Pierce	Pierce Height	
Inches	mm	(Cat. No.)	Volts(VDC)	(Amps)	Inches	Meters	Inches	mm	psi*	bar	Plasma	Total**	Delay (Sec)	Inches	mm
0,250	6,4	9-8212	120	100	120	3,05	0,180		65	4,5	105	360	0,2	0,225	5,7
0,375	9,5	9-8212	128	100	65	1,65	0,180		65	4,5	105	360	0,4	0,225	5,7
0,500	12,7	9-8212	130	100	45	1,15	0,180		65	4,5	105	360	0,5	0,225	5,7
0,625	15,9	9-8212	135	100	30	0,75	0,180		65	4,5	105	360	0,8	0,225	5,7
0,750	19,0	9-8212	140	100	25	0,65	0,180		65	4,5	105	360	1,0	0,225	5,7
1,000	25,4	9-8212	148	100	10	0,25	0,190		65	4,5	105	360	NR	NR	NR

Type Torch: SL100 With Shielded Tip							Type Material: Mild Steel								
Type Plasma Gas: Air							Type Secondary Gas: Single Gas Torch								
Thickness		Tip	Output	Amperage	Speed (Per Minute)		Standoff		Plasma Gas Press		Flow (CFH)		Pierce	Pierce Height	
Inches	mm	(Cat. No.)	Volts(VDC)	(Amps)	Inches	Meters	Inches	mm	psi*	bar	Plasma	Total**	Delay (Sec)	Inches	mm
0,250	6,4	9-8253	140	120	165	4,19	0,125	3,2	75	5,2	180	360	0,20	0,20	5,1
0,375	9,5	9-8253	142	120	85	2,16	0,125	3,2	75	5,2	180	360	0,50	0,20	5,1
0,500	12,7	9-8253	144	120	75	1,91	0,125	3,2	75	5,2	180	360	0,70	0,20	5,1
0,625	15,9	9-8253	150	120	50	1,27	0,125	3,2	75	5,2	180	360	0,80	0,20	5,1
0,750	19,0	9-8253	154	120	30	0,76	0,150	3,8	75	5,2	180	360	1,50	0,20	5,1
0,875	22,2	9-8253	158	120	25	0,64	0,150	3,8	75	5,2	180	360	NR	NR	NR
1,000	25,4	9-8253	160	120	20	0,51	0,150	3,8	75	5,2	180	360	NR	NR	NR
1,250	31,8	9-8253	170	120	13	0,33	0,175	4,4	75	5,2	180	360	NR	NR	NR
1,500	38,1	9-8253	176	120	8	0,20	0,175	4,4	75	5,2	180	360	NR	NR	NR

ESAB CUTMASTER 120

Type Torch: SL100 With Shielded Tip							Type Material: Stainless Steel								
Type Plasma Gas: Air							Type Secondary Gas: Single Gas Torch								
Thickness		Tip	Output	Amperage	Speed (Per Minute)		Standoff		Plasma Gas Press		Flow (CFH)		Pierce	Pierce Height	
Inches	mm	(Cat. No.)	Volts(VDC)	(Amps)	Inches	Meters	Inches	mm	psi*	bar	Plasma	Total**	Delay (Sec)	Inches	mm
0,250	6,4	9-8253	136	120	180	4,57	0,13	3,2	75	5,2	180	360	0,20	0,20	5,1
0,375	9,5	9-8253	144	120	100	2,54	0,13	3,2	75	5,2	180	360	0,40	0,20	5,1
0,500	12,7	9-8253	149	120	60	1,52	0,13	3,2	75	5,2	180	360	0,80	0,20	5,1
0,625	15,9	9-8253	153	120	40	1,02	0,15	3,8	75	5,2	180	360	1,20	0,20	5,1
0,750	19,1	9-8253	157	120	30	0,76	0,15	3,8	75	5,2	180	360	NR	NR	NR
1,000	25,4	9-8253	162	120	20	0,51	0,15	3,8	75	5,2	180	360	NR	NR	NR
1,250	31,8	9-8253	165	120	10	0,25	0,15	3,8	75	5,2	180	360	NR	NR	NR

Type Torch: SL100 With Shielded Tip							Type Material: Aluminum								
Type Plasma Gas: Air							Type Secondary Gas: Single Gas Torch								
Thickness		Tip	Output	Amperage	Speed (Per Minute)		Standoff		Plasma Gas Press		Flow (CFH)		Pierce	Pierce Height	
Inches	mm	(Cat. No.)	Volts(VDC)	(Amps)	Inches	Meters	Inches	mm	psi*	bar	Plasma	Total**	Delay (Sec)	Inches	mm
0,250	6,4	9-8253	144	120	190	4,83	0,13	3,2	75	5,2	180	360	0,20	0,20	5,1
0,375	9,5	9-8253	148	120	120	3,05	0,13	3,2	75	5,2	180	360	0,50	0,20	5,1
0,500	12,7	9-8253	152	120	75	1,91	0,15	3,8	75	5,2	180	360	0,70	0,20	5,1
0,625	15,9	9-8253	162	120	45	1,14	0,15	3,8	75	5,2	180	360	1,00	0,20	5,1
0,750	19,1	9-8253	163	120	35	0,89	0,15	3,8	75	5,2	180	360	NR	NR	NR
1,000	25,4	9-8253	168	120	20	0,51	0,15	3,8	75	5,2	180	360	NR	NR	NR



NOTE!

* Gas pressure shown is for torches with leads up to 25' / 7.6 m long. For 50' / 15.2 m leads, refer to Section "Set Operating Pressure" on page <?>.

** Total flow rate includes plasma and secondary gas flow.

This Page Intentionally Blank

PATENT INFORMATION

Plasma Cutting Torch Patents

The following parts are covered under U.S. and Foreign Patents as follows:

Catalog #	Description	Patent(s)
9-8215	Electrode	US Pat No(s) 6163008; 6987238 Other Pat(s) Pending
9-8213	Cartridge	US Pat No(s) 6903301; 6717096; 6936786; 6703581; D496842; D511280; D492709; D499620; D504142 Other Pat(s) Pending
9-8205	Tip	US Pat No(s) 6774336; 7145099; 6933461 Other Pat(s) Pending
9-8206	Tip	US Pat No(s) 6774336; 7145099; 6933461 Other Pat(s) Pending
9-8207	Tip	US Pat No(s) 6774336; 7145099; 6933461 Other Pat(s) Pending
9-8252	Tip	US Pat No(s) 6774336; 7145099; 6933461 Other Pat(s) Pending
9-8208	Tip	US Pat No(s) 6774336; 7145099; 6933461 Other Pat(s) Pending
9-8209	Tip	US Pat No(s) 6774336; 7145099; 6933461 Other Pat(s) Pending
9-8210	Tip	US Pat No(s) 6774336; 7145099; 6933461 Other Pat(s) Pending
9-8231	Tip	US Pat No(s) 6774336; 7145099; 6933461 Other Pat(s) Pending
9-8211	Tip	US Pat No(s) 6774336; 7145099; 6933461 Other Pat(s) Pending
9-8212	Tip	US Pat No(s) 6774336; 7145099; 6933461 Other Pat(s) Pending
9-8253	Tip	US Pat No(s) 6774336; 7145099; 6933461 Other Pat(s) Pending
9-8225	Tip	US Pat No(s) 6774336; 7145099; 6933461 Other Pat(s) Pending
9-8226	Tip	US Pat No(s) 6774336; 7145099; 6933461 Other Pat(s) Pending
9-8227	Tip	US Pat No(s) 6774336; 7145099; 6933461 Other Pat(s) Pending
9-8228	Tip	US Pat No(s) 6774336; 7145099; 6933461 Other Pat(s) Pending
9-8241	Shield Cap	US Pat No(s) 6914211; D505309 Other Pat(s) Pending
9-8243	Shield Cap	US Pat No(s) 6914211; D493183 Other Pat(s) Pending
9-8235	Shield Cap	US Pat No(s) 6914211; D505309 Other Pat(s) Pending
9-8236	Shield Cap	US Pat No(s) 6914211; D505309 Other Pat(s) Pending
9-8237	Shield Cup	US Pat No(s) 6914211; D501632; D511633 Other Pat(s) Pending
9-8238	Shield Cap	US Pat No(s) 6914211; D496951 Other Pat(s) Pending
9-8239	Shield Cap	US Pat No(s) 6914211; D496951 Other Pat(s) Pending
9-8244	Shield Cap	US Pat No(s) 6914211; D505309 Other Pat(s) Pending

ESAB CUTMASTER 120

Catalog #	Description	Patent(s)
9-8245	Shield Cap	US Pat No(s) 6914211; D496951 Other Pat(s) Pending

The following parts are also licensed under U.S. Patent No. 5, 120, 930 and 5, 132, 512:

Catalog #	Description
9-8235	Shield Cap
9-8236	Shield Cap
9-8237	Shield Cup
9-8238	Shield Cap
9-8239	Shield Cap
9-8244	Shield Cap
9-8245	Shield Cap

This Page Intentionally Blank

SECTION 5 SYSTEM: SERVICE

5.01 General Maintenance



Warning!
Disconnect input power before maintaining.

Maintain more often
if used under severe
conditions

Each Use

Visual check of
torch tip and electrode

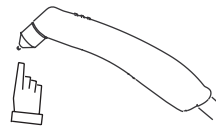

Weekly

Visually inspect the torch body tip,
electrode, start cartridge and shield cup



Visually inspect the
cables and leads.
Replace as needed

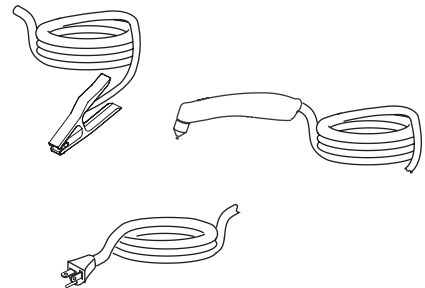

3 Months

Replace all
broken parts

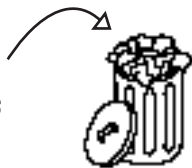

Clean
exterior
of power supply

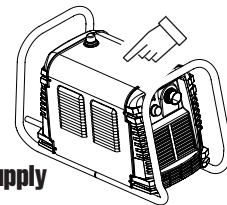

6 Months

Visually check and
Carefully clean the
interior

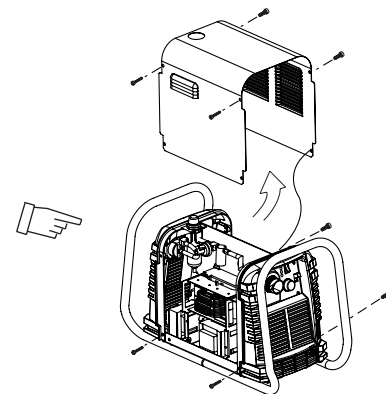

ESAB CUTMASTER 120

5.02 Maintenance Schedule



NOTE!

The actual frequency of maintenance may need to be adjusted according to the operating environment.

Daily Operational Checks or Every Six Cutting Hours:

1. Check torch consumable parts, replace if damaged or worn.
2. Check plasma and secondary supply and pressure/flow.
3. Purge plasma gas line to remove any moisture build-up.

Weekly or Every 30 Cutting Hours:

1. Check fan for proper operation and adequate air flow.
2. Inspect torch for any cracks or exposed wires, replace if necessary.
3. Inspect input power cable for damage or exposed wires, replace if necessary.

Six Months or Every 720 Cutting Hours:

1. Check the in-line air filter(s), clean or replace as required.
2. Check cables and hoses for leaks or cracks, replace if necessary.
3. Check all contactor points for severe arcing or pits, replace if necessary.
4. Vacuum dust and dirt out of the entire machine.



CAUTION

Do not blow air **into** the power supply during cleaning. Blowing air into the unit can cause metal particles to interfere with sensitive electrical components and cause damage to the unit.

5.03 Common Faults

Problem - Symptom	Common Cause
Insufficient Penetration	<ol style="list-style-type: none">1. Cutting speed too fast.2. Torch tilted too much.3. Metal too thick.4. Worn torch parts5. Cutting current too low.6. Non - Genuine ESAB parts used7. Incorrect gas pressure
Main Arc Extinguishes	<ol style="list-style-type: none">1. Cutting speed too slow.2. Torch standoff too high from workpiece.3. Cutting current too high.4. Work cable disconnected.5. Worn torch parts.6. Non - Genuine ESAB parts used
Excessive Dross Formation	<ol style="list-style-type: none">1. Cutting speed too slow.2. Torch standoff too high from workpiece.3. Worn torch parts.4. Improper cutting current.5. Non - Genuine ESAB parts used6. Incorrect gas pressure
Short Torch Parts Life	<ol style="list-style-type: none">1. Oil or moisture in air source.2. Exceeding system capability (material too thick).3. Excessive pilot arc time4. Gas pressure too low.5. Improperly assembled torch.6. Non - Genuine ESAB parts used
Difficult Starting	<ol style="list-style-type: none">1. Worn torch parts.2. Non - Genuine ESAB parts used.3. Incorrect gas pressure.

5.04 Fault Indicator

At initial power up, two lights will temporarily illuminate for 2-3 seconds to show the version of software used.

To determine the first digit, count the function indicators left to right, 1 through 5. To determine the second digit count the pressure indicators, reading from bottom to top, 0 through 7. In the example below the Temp indicator and 75 psi indicators are on indicating the version would be 2.3.

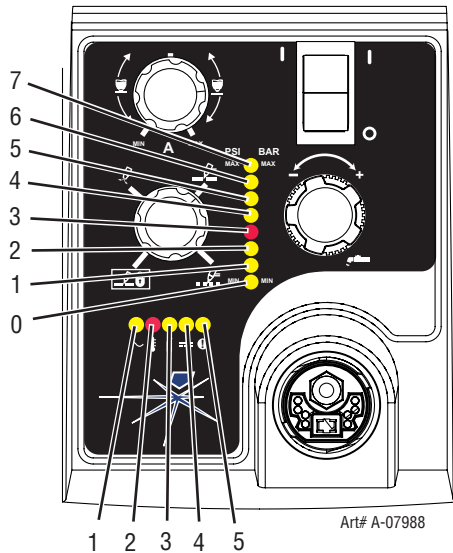

When the "Fault" indicator is ON or blinking it will be accompanied by one of the pressure indicator lights depending on what the Fault is. The following table explains each of those Faults.

Pressure Indicator	Fault
Max	Over Pressure
90	Internal Error
85	Check Consumables
80	Consumables Missing
75	Start Error
70	Parts in Place
65	Input Power
Min	Under Pressure



NOTE!

Fault explanations are covered in the following tables.

ESAB CUTMASTER 120

5.05 Basic Troubleshooting Guide



WARNING

There are extremely dangerous voltage and power levels present inside this unit. Do not attempt to diagnose or repair unless you have had training in power electronics measurement and troubleshooting techniques.

Problem - Symptom	Possible Cause	Recommended Action
ON / OFF Switch is ON but the A/C Indicator does not light	<ol style="list-style-type: none"> 1. Primary power disconnect is in OFF position. 2. Primary fuses / breakers are blown or tripped. 3. Units internal fuse blown. 4. Faulty components in unit. 	<ol style="list-style-type: none"> 1. Turn primary power disconnect switch to ON position. 2. a) Have qualified person check primary fuses / breakers. b) Connect unit to known good primary power receptacle 3. a) Replace fuse. b) If fuse blows again, return to authorized service center for repair or replacement. 4. Return to authorized service center for repair or replacement.
Fault indicator flashing, 65 PSI indicator flashing	<ol style="list-style-type: none"> 1. Improper Input Voltage. 2. Primary input voltage problem. 3. Faulty components in unit. 	<ol style="list-style-type: none"> 1. Check for proper primary input voltage. 2. Have qualified person check primary voltage to insure it meets unit requirements see section 2.05. 3. Return to authorized service center for repair or replacement.
TEMPERATURE indicator ON. FAULT indicator flashing.	<ol style="list-style-type: none"> 1. Air flow through or around the unit is obstructed. 2. Duty cycle of the unit has been exceeded 3. Failed components in unit 	<ol style="list-style-type: none"> 1. Refer to clearance information – section 2.04 2. Allow unit to cool. 3. Return to authorized service center for repair or replacement.
GAS LED OFF, FAULT and MIN pressure indicators flashing.	<ol style="list-style-type: none"> 1. Gas supply not connected to unit. 2. Gas supply not turned ON. 3. Gas supply pressure too low. 4. AIR PRESSURE CONTROL regulator set too low. 5. Failed components in unit. 	<ol style="list-style-type: none"> 1. Connect gas supply to unit. 2. Turn gas supply ON. 3. Set air supply inlet pressure to unit to 120 psi. 4. Adjust regulator to set air pressure - see section 4.02. 5. Return to authorized service center for repair or replacement.
FAULT and 70 PSI indicators flashing.	<ol style="list-style-type: none"> 1. Shield Cup loose. 2. Torch not properly connected to power supply. 3. Problem in torch and leads PIP circuit. 4. Failed components in unit. 	<ol style="list-style-type: none"> 1. Hand tighten the shield cup until it is snug. 2. Insure torch ATC is securely fastened to unit. 3. Replace torch and leads or return to authorized service center for repair or replacement. 4. Return to authorized service center for repair or replacement.
FAULT and 75 PSI indicators flashing.	<ol style="list-style-type: none"> 1. Start signal is active when ON/OFF SWITCH is turned to ON position. 2. Problem in the torch and leads switch circuit. 3. Failed components in unit. 	<ol style="list-style-type: none"> 1. Start can be active for one of the following: <ul style="list-style-type: none"> • Hand torch switch held closed • Hand pendant switch held closed • CNC START signal is active low Release the START signal source 2. Replace torch and leads or return to authorized service center for repair or replacement. 3. Return to authorized service center for repair or replacement.

Problem - Symptom	Possible Cause	Recommended Action
FAULT & 80 PSI indicators flashing. Gas flow is cycling ON and OFF.	<ol style="list-style-type: none"> 1. Torch shield cup is loose. 2. Torch tip, electrode or starter cartridge missing. 3. Torch starter cartridge is stuck. 4. Open conductor in torch leads. 5. Problem in the torch and leads switch circuit. 6. Failed components in unit. 	<ol style="list-style-type: none"> 1. Tighten shield cup by hand. Do not overtighten. 2. Turn OFF power supply. Remove shield cup. Install missing parts. 3. Turn OFF power supply. Bleed down system pressure. Remove shield cup, tip and starter cartridge. Check starter cartridge lower end fitting for free movement. Replace if fitting does not move freely. 4. Replace torch and leads or return to authorized service center for repair or replacement. 5. Replace torch and leads or return to authorized service center for repair or replacement. 6. Return to authorized service center for repair or replacement.
Nothing happens when torch switch or remote switch is closed (Or CNC START signal is active) No gas flow, DC LED OFF.	<ol style="list-style-type: none"> 1. Problem in the torch and leads switch circuit (Remote pendant switch circuit). 2. CNC Controller device not providing Start signal. 3. Failed components in unit. 	<ol style="list-style-type: none"> 1. Take Torch and Leads (Remote Pendant) to Authorized Repair Facility. 2. Contact Controller manufacturer. 3. Return to authorized service center for repair or replacement.
FAULT and 85 PSI indicators flashing.	<ol style="list-style-type: none"> 1. Upper O-Ring on torch head is in wrong position. 2. Torch starter cartridge is stuck. 3. Worn or faulty torch parts. 4. Shorted Torch. 5. Temporary Short indicated by 5 blinks per second. 6. Power Supply Failure (Standard rate of blinking) 	<ol style="list-style-type: none"> 1. Remove shield cup from torch; check upper O-Ring position; correct if necessary. 2. Turn OFF power supply. Bleed down system pressure. Remove shield cup, tip and starter cartridge. Check starter cartridge lower end fitting for free movement. Replace if fitting does not move freely. 3. Inspect torch consumable parts. Replace if necessary. 4. Replace torch and leads or return to an authorized service center for repair. 5. Release torch switch and reactivate. 6. Return to authorized service center for repair or replacement.
No Fault lights ON, no arc in torch.	<ol style="list-style-type: none"> 1. Failed components in unit. 	<ol style="list-style-type: none"> 1. Return to an authorized service center for repair.
Fault and 90 PSI indicators flashing	<ol style="list-style-type: none"> 1. Internal Error 	<ol style="list-style-type: none"> 1. Turn the ON / OFF switch OFF then back ON again. If that does not clear the fault, return to an authorized service center for repair.
Pilot arc is ON but cutting arc will not establish	<ol style="list-style-type: none"> 1. Work cable not connected to work piece. 2. Work cable/connector broken. 3. Failed components in unit. 	<ol style="list-style-type: none"> 1. Connect work cable. 2. Replace work cable. 3. Return to an authorized service center for repair.
Torch cutting is diminished	<ol style="list-style-type: none"> 1. Incorrect current setting. 2. Worn torch consumables. 3. Poor work cable connection to work piece. 4. Torch being moved too fast. 5. Excessive oil or water in torch. 6. Failed components in unit. 	<ol style="list-style-type: none"> 1. Check and adjust to proper setting. 2. Check torch consumables and replace as needed. 3. Check the connection of the Work Lead to the work piece. 4. Reduce cutting speed. 5. Refer to "Check air quality" in section 3 Torch. 6. Return to an authorized service center for repair.

ESAB CUTMASTER 120

5.06 Power Supply Basic Parts Replacement



WARNING

Disconnect primary power to the system before disassembling the torch, leads, or power supply.

This section describes procedures for basic parts replacement. For more detailed parts replacement procedures, refer to the Power Supply Service Manual.

A. Cover Removal

1. Remove the NOTE screws which secure the cover to the main assembly. Do not loosen the lower screws inside the cut out slots in the bottom of the cover.

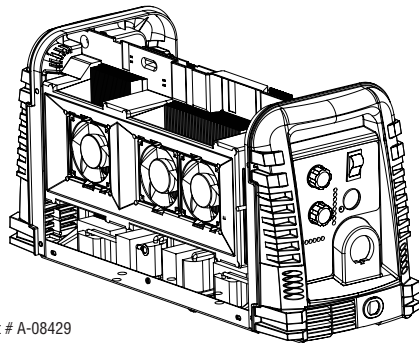
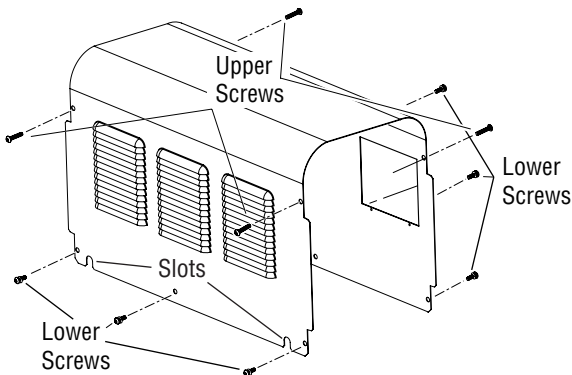

2. Carefully pull the Cover up and away from the unit.

B. Cover Installation

1. Reconnect the ground wire, if necessary.
2. Place the cover onto the power supply so that slots in the bottom edges of the cover engage the lower screws.
3. Tighten lower screws.
4. Reinstall and tighten the upper screws.

C. Filter Element Assembly Replacement

The Filter Element Assembly is in the rear panel. For better system performance, the filter element should be checked per the Maintenance Schedule (Subsection 5.02), and either cleaned or replaced.

1. Remove power from the power supply; turn OFF the gas supply and bleed down the system.
2. Remove the system cover. See "A Cover Removal" in this section.
3. Locate the internal air line and the fitting from the filter assembly. Number 1 in the following illustration.
4. Hold a wrench or similar tool against the locking ring on the filter assembly fitting, then pull on the hose to release it. (Numbers 2 and 3 in the following illustration).

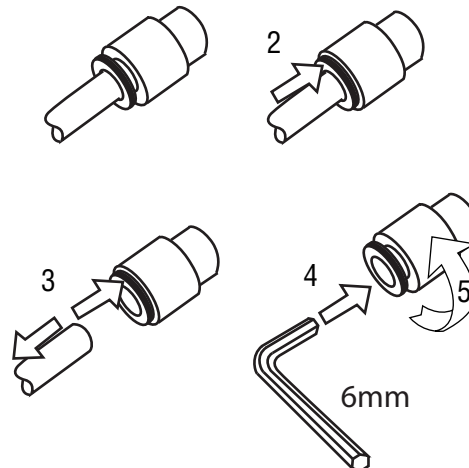
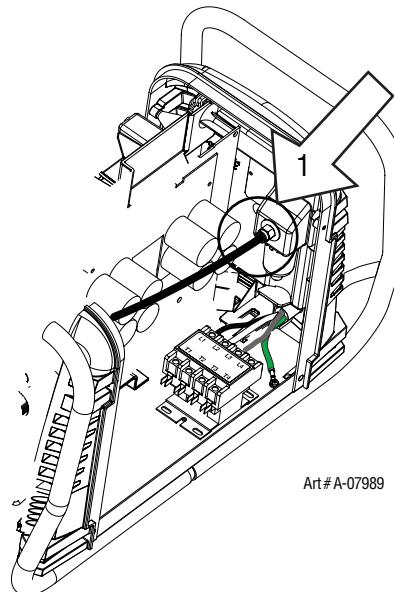

5. Remove the fitting from the filter element assembly by inserting a 6 mm hex wrench into the internal hex fitting and turning it counter clockwise (left). Numbers 4 and 5 in the previous illustration.

6. Disconnect the input line from the filter element assembly.
7. Remove the filter element assembly through the rear opening.

i NOTE!
If replacing or cleaning just the filter element refer to the following illustration for disassembly.

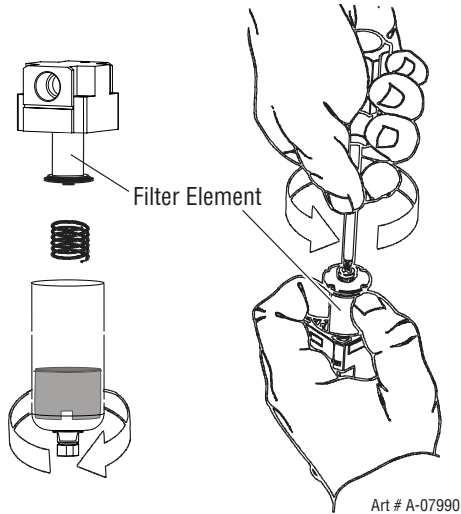

8. Install the new or cleaned assembly by reversing these procedures.
9. Turn ON the air supply and check for leaks before reinstalling the cover.

Optional Single-Stage Filter Element Replacement

These instructions apply to power supplies where the optional Single-Stage Filter has been installed.

The Power Supply shuts down automatically when the Filter Element becomes completely saturated. The Filter Element can be removed from its housing, dried, and reused. Allow 24 hours for Element to dry. Refer to Section 6, Parts List, for replacement filter element catalog number.

1. Remove power from power supply.
2. Shut OFF air supply and bleed down system before disassembling Filter to change Filter Element.
3. Disconnect gas supply hose.
4. Turn the Filter Housing Cover counter-clockwise and remove it. The Filter Element is located inside the Housing.

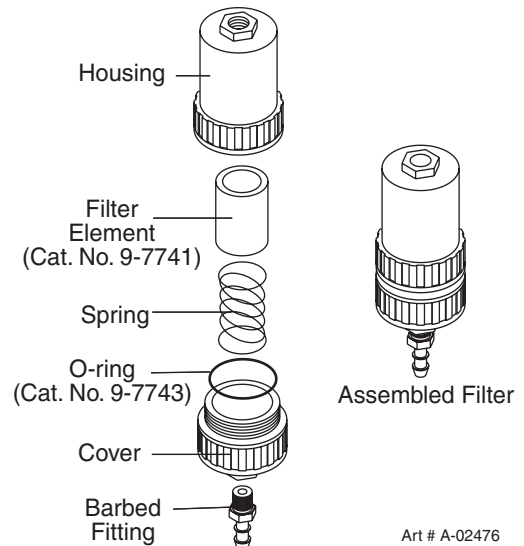

Optional Single-Stage Filter Element Replacement

5. Remove the Filter Element from the Housing and set Element aside to dry.
6. Wipe inside of housing clean, then insert the replacement Filter Element open side first.
7. Replace Housing on Cover.
8. Reattach gas supply.

i NOTE!
If unit leaks between housing and cover, inspect the O-ring for cuts or other damage.

ESAB CUTMASTER 120

Optional Two-Stage Filter Element Replacement

The Two-Stage Air Filter has two Filter Elements. When the Filter Elements become dirty the Power Supply will continue to operate but cut quality may become unacceptable. Refer to Section 6, Parts List, for replacement filter element catalog number.

1. Shut OFF primary input power.
2. Shut OFF air supply and bleed down system.



WARNING

Always turn OFF the air supply and bleed the system before disassembling the Filter Assembly as injury could result.

3. Loosen the two bolts on the top of the Filter Assembly enough to allow the Filter Elements to move freely.
4. Note the location and orientation of the old Filter Elements.
5. Slide out the old Filter Elements.

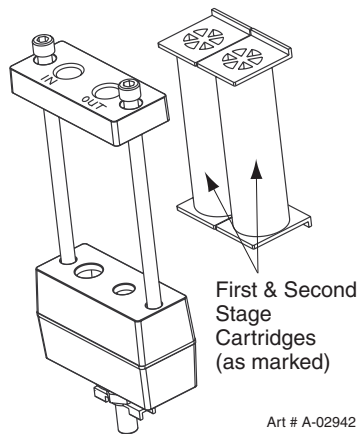

Optional Two-Stage Filter Replacement

6. Slide the replacement Filter Elements into the Filter Assembly, with the same orientation as noted in Step 4 above.
7. Hand tighten the two bolts evenly, then torque each bolt to 20 - 30 in-lbs (2.3 - 3.4 Nm). Improper torque may damage the gasket.
8. Slowly apply air pressure to the assembly, checking for leaks.



NOTE!

A small amount of air leakage from the bottom fitting is normal.

This completes the parts replacement procedures.

SECTION 5 TORCH: SERVICE

5T.01 General Maintenance



NOTE!

Refer to Previous "Section 5: System" for common and fault indicator descriptions.

Cleaning Torch

Even if precautions are taken to use only clean air with a torch, eventually the inside of the torch becomes coated with residue. This buildup can affect the pilot arc initiation and the overall cut quality of the torch.



WARNING

Disconnect primary power to the system before disassembling the torch or torch leads. DO NOT touch any internal torch parts while the AC indicator light of the Power Supply is ON.

The inside of the torch should be cleaned with electrical contact cleaner using a cotton swab or soft wet rag. In severe cases, the torch can be removed from the leads and cleaned more thoroughly by pouring electrical contact cleaner into the torch and blowing it through with compressed air.



CAUTION

Dry the torch thoroughly before reinstalling.

O-Ring Lubrication

An o-ring on the Torch Head and ATC Male Connector requires lubrication on a scheduled basis. This will allow the o-rings to remain pliable and provide a proper seal. The o-rings will dry out, becoming hard and cracked if the lubricant is not used on a regular basis. This can lead to potential performance problems.

It is recommended to apply a very light film of o-ring lubricant (Catalog # 8-4025) to the o-rings on a weekly basis.

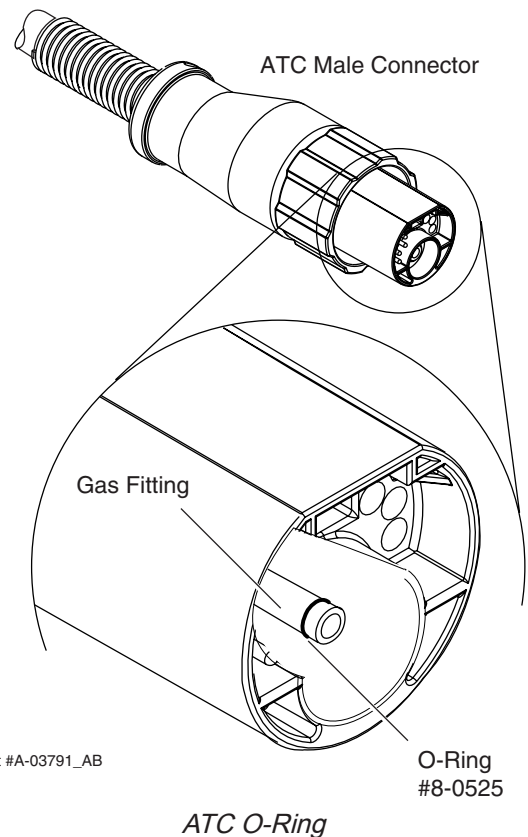
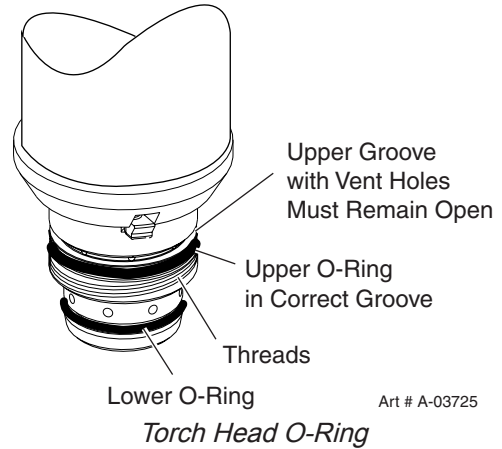

NOTE!

DO NOT use other lubricants or grease, they may not be designed to operate within high temperatures or may contain "unknown elements" that may react with the atmosphere. This reaction can leave contaminants inside the torch. Either of these conditions can lead to inconsistent performance or poor parts life.

ESAB CUTMASTER 120

5T.02 Inspection and Replacement of Consumable Torch Parts



WARNING

Disconnect primary power to the system before disassembling the torch or torch leads. DO NOT touch any internal torch parts while the AC indicator light of the Power Supply is ON.

Remove the consumable torch parts as follows:



NOTE!

The shield cup holds the tip and starter cartridge in place. Position the torch with the shield cup facing upward to prevent these parts from falling out when the cup is removed.

1. Unscrew and remove the shield cup from the torch.



NOTE!

Slag built up on the shield cup that cannot be removed may effect the performance of the system.

2. Inspect the cup for damage. Wipe it clean or replace if damaged.

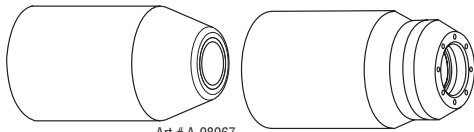

Art # A-08067

Shield Cups

3. On torches with a shield cup body and a shield cap or deflector, ensure that the cap or deflector is threaded snugly against the shield cup body. In shielded drag cutting operations (only), there may be an O-ring between the shield cup body and drag shield cap. Do not lubricate the O-ring.

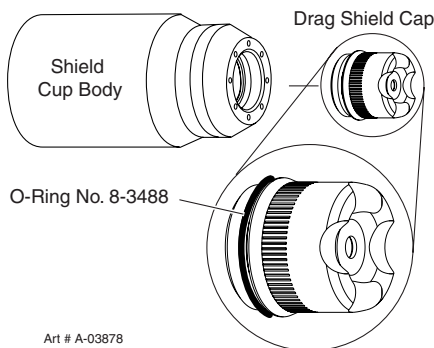

Art # A-03878

4. Remove the tip. Check for excessive wear (indicated by an elongated or oversized orifice). Clean or replace the tip if necessary.

Good Tip

Worn Tip

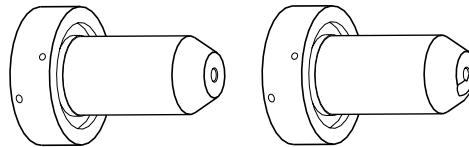

A-03406

Example of Tip Wear

5. Remove the starter cartridge. Check for excessive wear, plugged gas holes, or discoloration. Check the lower end fitting for free motion. Replace if necessary.

Spring-Loaded Lower End Fitting Full Compression

Spring-Loaded Lower End Fitting at Reset Full Extension

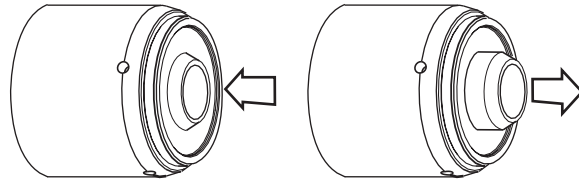

Art # A-08064_AC

6. Pull the Electrode straight out of the Torch Head. Check the face of the electrode for excessive wear. Refer to the following figure.

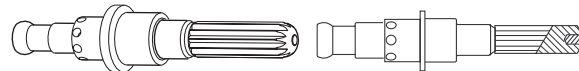

New Electrode

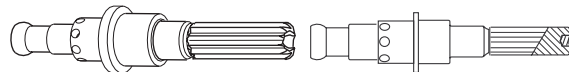

Worn Electrode

Art # A-03284

Electrode Wear

7. Reinstall the Electrode by pushing it straight into the torch head until it clicks.
8. Reinstall the desired starter cartridge and tip into the torch head.
9. Hand tighten the shield cup until it is seated on the torch head. If resistance is felt when installing the cup, check the threads before proceeding.

This completes the parts replacement procedures.

SECTION 6: PARTS LISTS

6.01 Introduction

A. Parts List Breakdown

The parts list provide a breakdown of all replaceable components. The parts lists are arranged as follows:

Section "6.03 Power Supply Replacement"

Section "6.04 Replacement Power Supply Parts"

Section "6.05 Options and Accessories"

Section "6.06 Replacement Parts for Hand Torch"

Section "6.07 Replacement Parts - for Machine Torches with Unshielded Leads"

Section "6.08 Torch Consumable Parts (SL100)"



NOTE!

Parts listed without item numbers are not shown, but may be ordered by the catalog number shown.

B. Returns

If a product must be returned for service, contact your distributor. Materials returned without proper authorization will not be accepted.

6.02 Ordering Information

Order replacement parts by catalog number and complete description of the part or assembly, as listed in the parts list for each type item. Also include the model and serial number of the power supply. Address all inquiries to your authorized distributor.

6.03 Power Supply Replacement

The following items are included with the replacement power supply: work cable & clamp, input power cable, gas pressure regulator / filter, and operating manual.

Qty	Description	Catalog #
	ESAB Cutmaster 120 CE Power Supply with 400VAC, 3 phase 50/60 Hz with input power cable	0559319304

6.04 Replacement Power Supply Parts

Qty	Description	Catalog #
1	Regulator	9-0115
1	Filter Assembly Replacement Element	9-0116
1	Input Power Cord for 380/400 V Power Supply	9-0216

ESAB CUTMASTER 120

6.05 Options and Accessories

Qty	Description	Catalog #
1	Single - Stage Filter Kit (includes Filter & Hose)	7-7507
1	Replacement Filter Body	9-7740
1	Replacement Filter Hose (not shown)	9-7742
2	Replacement Filter Element	9-7741
1	Two - Stage Filter Kit (includes Hose & Mounting Screws)	9-9387
1	Two - Stage Air Filter Assembly	9-7527
1	First Stage Cartridge	9-1021
1	Second Stage Cartridge	9-1022
1	Extended Work Cable (50 ft / 15.2 m) with Clamp	9-8529
1	Automation Interface Kit for Start/Stop, OK to move and Divided Arc Voltage)	9-8311
1	Automation Harness for Start/Stop and OK to move	9-9385
1	25' / 7.6 m CNC Cable for Automation Interface Kit	9-1008
1	35' / 10.7 m CNC Cable for Automation Interface Kit	9-1010
1	50' / 15.2 m CNC Cable for Automation Interface Kit	9-1011
1	Remote pendant	7-3460
1	Simple Automation Interface	9-9385

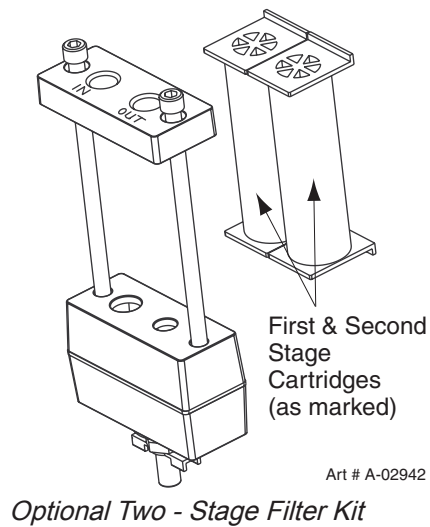
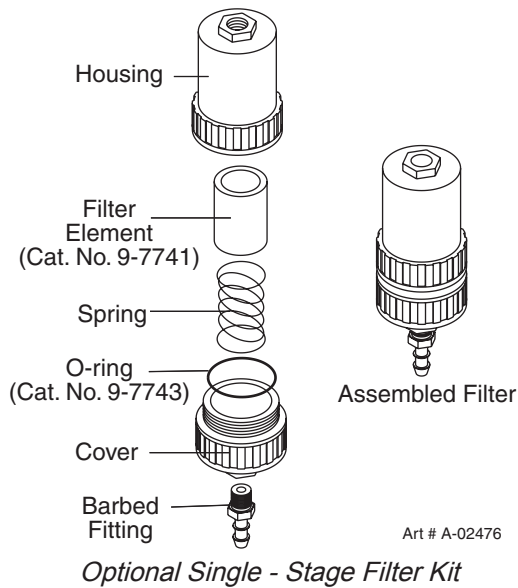

6.06 Replacement Parts for Hand Torch

Item #	Qty	Description	Catalog #
1	1	Torch Handle Replacement Kit (includes items No. 2 & 3)	9-7030
2	1	Trigger Assembly Replacement Kit	9-7034
3	1	Handle Screw Kit (5 each, 6-32 x 1/2" cap screw, and wrench)	9-8062
4	1	Torch Head Assembly Replacement Kit (includes items No. 5 & 6)	9-8219
5	1	Large O-Ring	8-3487
6	1	Small O-Ring	8-3486
7		Leads Assemblies with ATC connectors (includes switch assemblies)	
	1	SL100, 20 - foot Leads Assembly with ATC connector	4-7836
	1	SL100, 50 - foot Leads Assembly with ATC connector	4-7837
8	1	Switch Kit	9-7031
10	1	Torch Control Cable Adapter (includes item # 11)	7-3447
11	1	Through - Hole Protector	9-8103

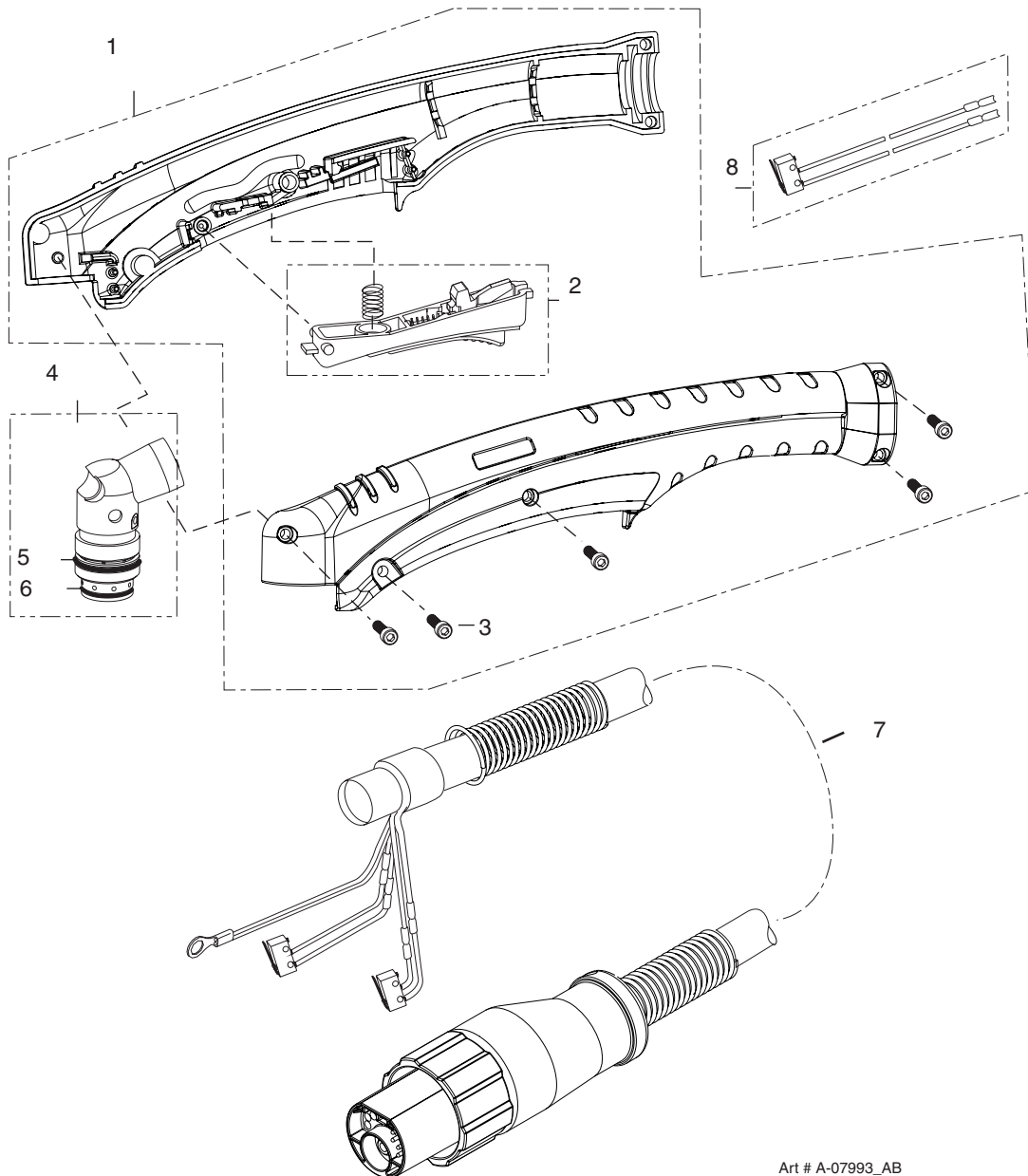

Art # A-07993_AB

ESAB CUTMASTER 120

6.07 Replacement Parts - for Machine Torches with Unshielded Leads

Item No.	Qty	Description	Catalog #
1	1	Torch Head Assembly without leads (includes items 2, 3, and 14)	9-8220
2	1	Large O-Ring	8-3487
3	1	Small O-Ring	8-3486
4	1	PIP Switch Kit	9-7036
5		Unshielded Automated Leads Assemblies with ATC connectors	
	1	5 - foot / 1.5 m Leads Assembly with ATC connector	4-7850
	1	10 - foot / 3.05 m Leads Assembly with ATC connector	4-7851
	1	25 - foot / 7.6 m Leads Assembly with ATC connector	4-7852
	1	50 - foot / 15.2 m Leads Assembly with ATC connector	4-7853
6		Unshielded Mechanized Leads Assemblies with ATC connectors	
	1	5 - foot / 1.5 m Leads Assembly with ATC connector	4-7842
	1	10 - foot / 3.05 m Leads Assembly with ATC connector	4-7843
	1	25 - foot / 7.6 m Leads Assembly with ATC connector	4-7844
	1	50 - foot / 15.2 m Leads Assembly with ATC connector	4-7845
7	1	11" / 279 mm Rack	9-7041
8	1	11" / 279 mm Mounting Tube	9-7043
9	1	End Cap Assembly	9-7044
10	2	Body, Mounting, Pinch Block	9-4513
11	1	Pin, Mounting, Pinch Block	9-4521
12	1	Torch Holder Sleeve	7-2896
13	1	PIP Plunger and Return Spring Kit	9-7045
	1	Pinion Assembly (Not shown)	7-2827
	1	5" / 126 mm Positioning Tube (Not shown)	9-7042



NOTE!

*Does not include Control Cable Adapter or Through - Hole Protector.

ESAB CUTMASTER 120

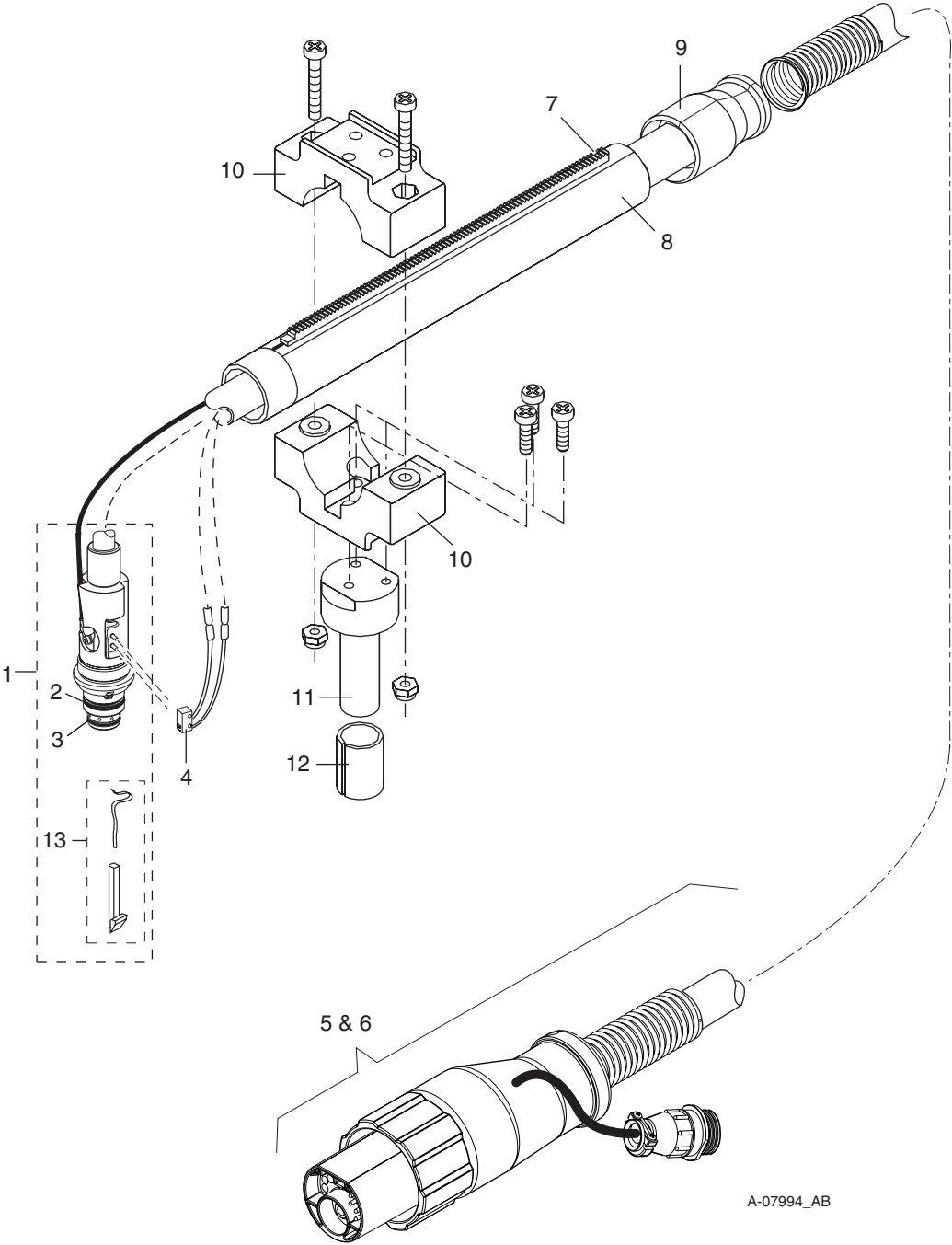

A-07994_AB

ESAB CUTMASTER 120

6.08 Torch Consumable Parts (SL100)

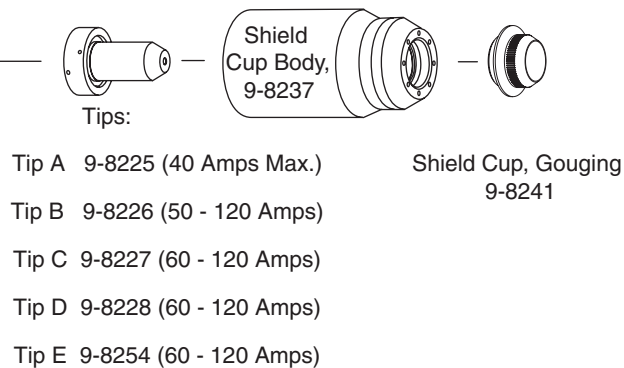
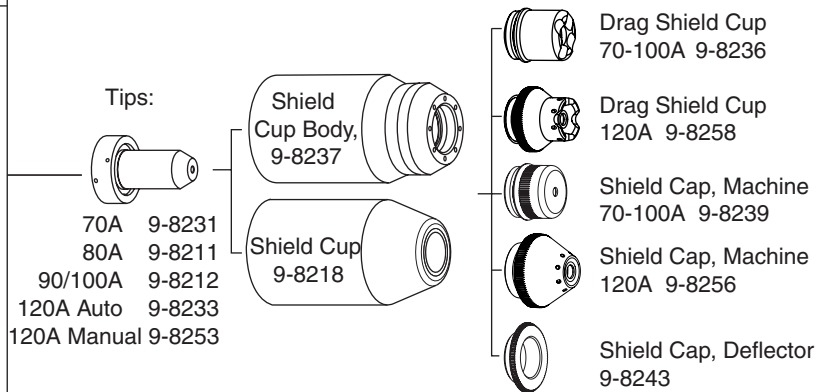
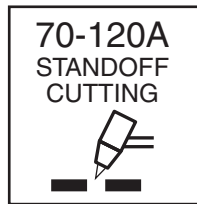
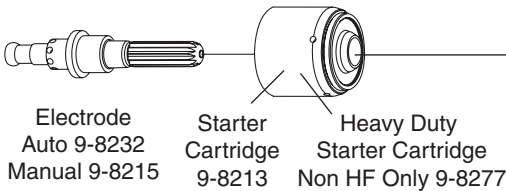
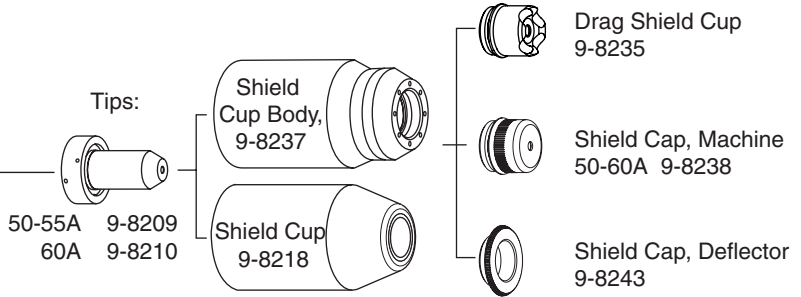
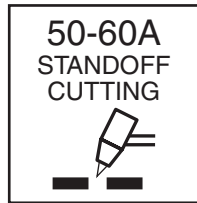
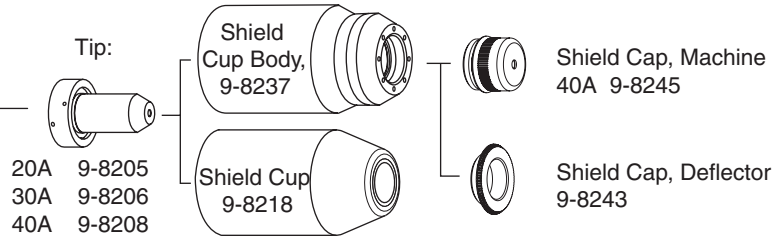
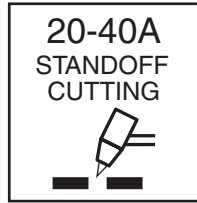
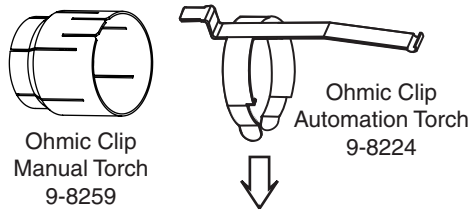

Art # A-08066_AG

APPENDIX 1: SEQUENCE OF OPERATION (BLOCK DIAGRAM)

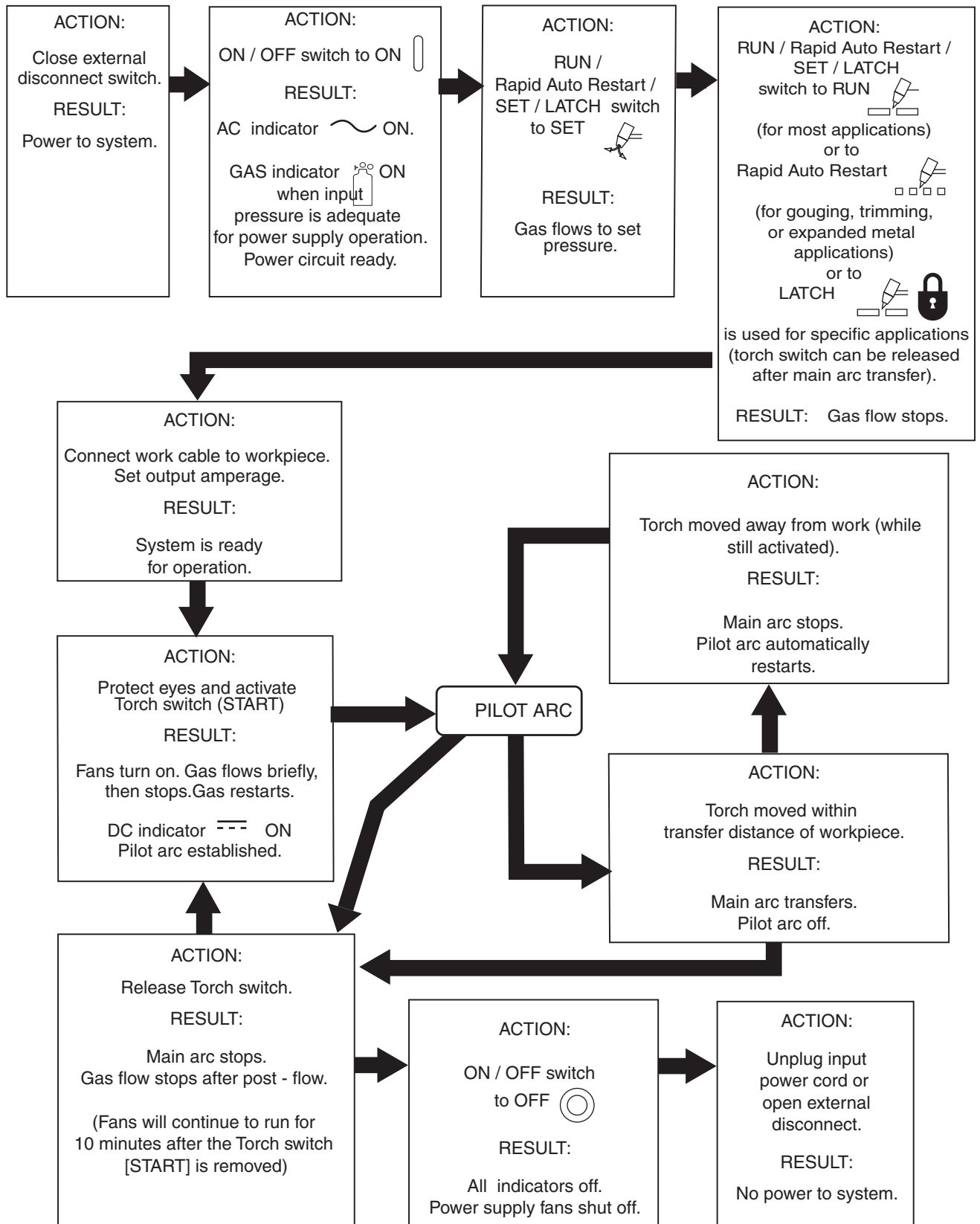

Art #A-07979_AB

APPENDIX 2: DATA TAG INFORMATION

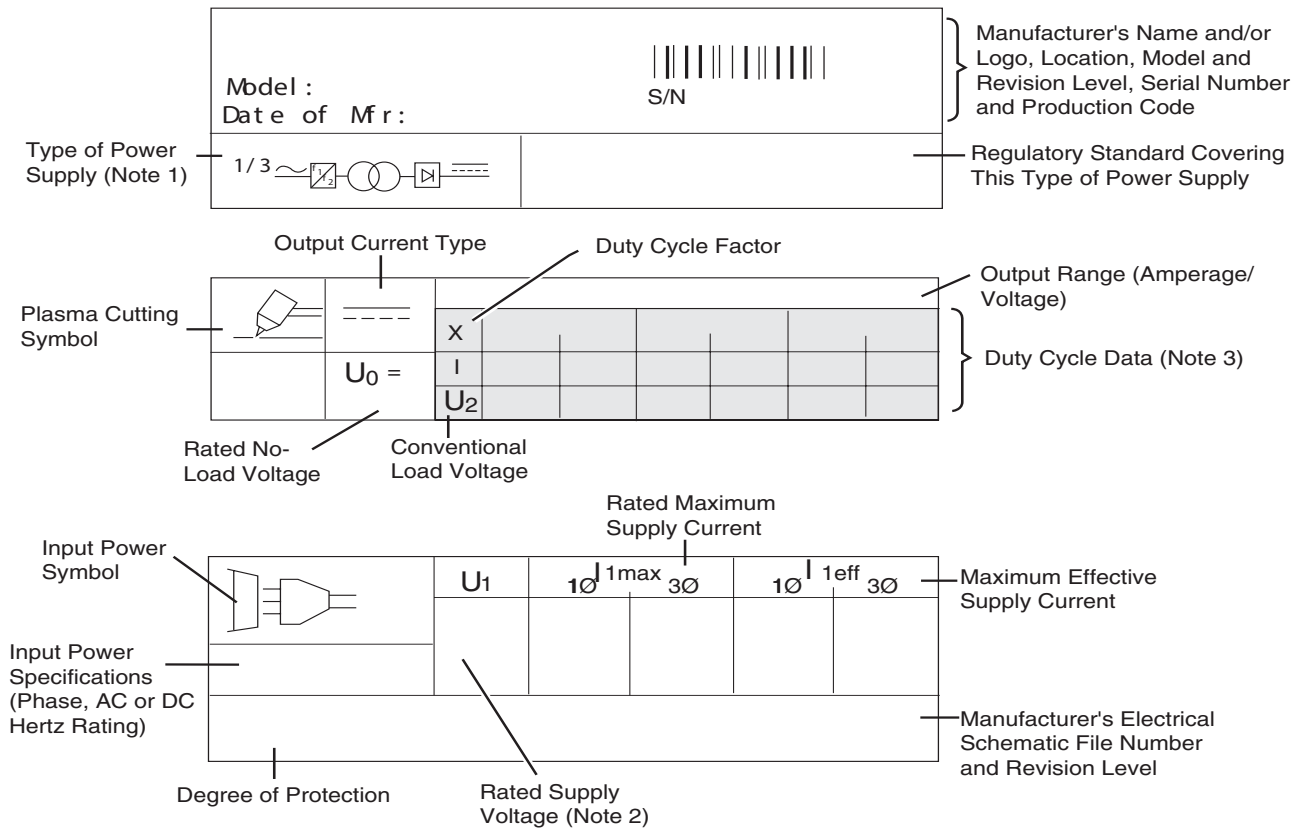

NOTES:

1. Symbol shown indicates single- or three-phase AC input, static frequency converter-transformer-rectifier, DC output.
2. Indicates input voltages for this power supply. Most power supplies carry a label at the input power cord showing input voltage requirements for the power supply as built.
3. Top row: Duty cycle values.
IEC duty cycle value is calculated as specified by the International ElectroTechnical Commission.
TDC duty cycle value is determined under the power supply manufacturer's test procedures.
Second row: Rated cutting current values.
Third row: Conventional load voltage values.
4. Sections of the Data Tag may be applied to separate areas of the power supply.

Standard Symbols

- ~ AC
- DC
- ∅ Phase

Art # A-12765_AA

APPENDIX 3: TORCH PIN - OUT DIAGRAMS

A. Hand Torch Pin - Out Diagram

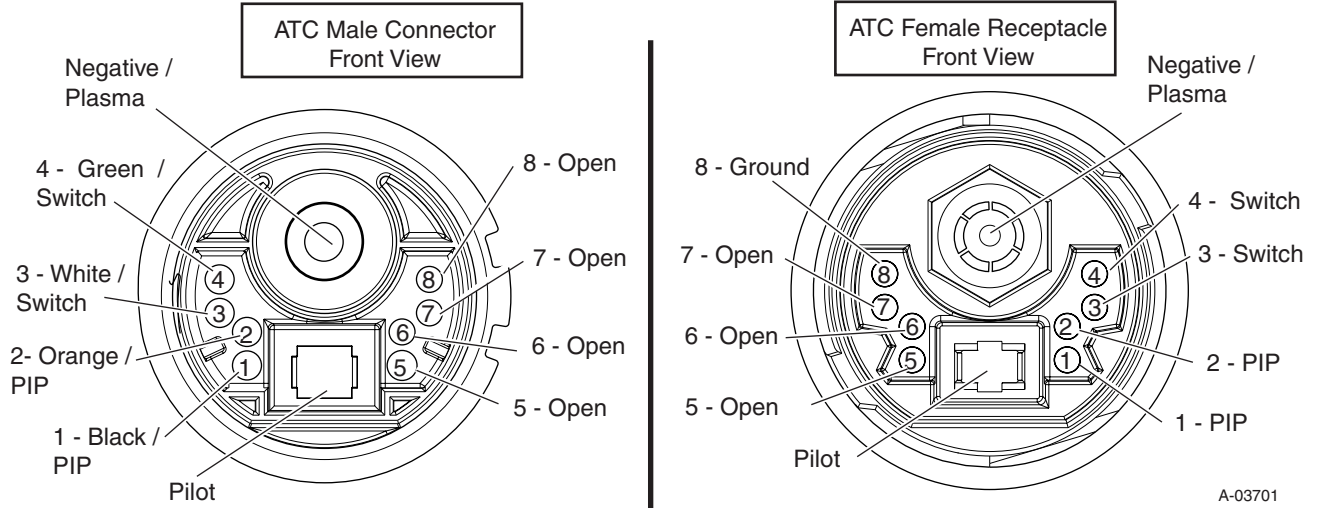

B. Mechanized (Machine) Torch Pin - Out Diagram

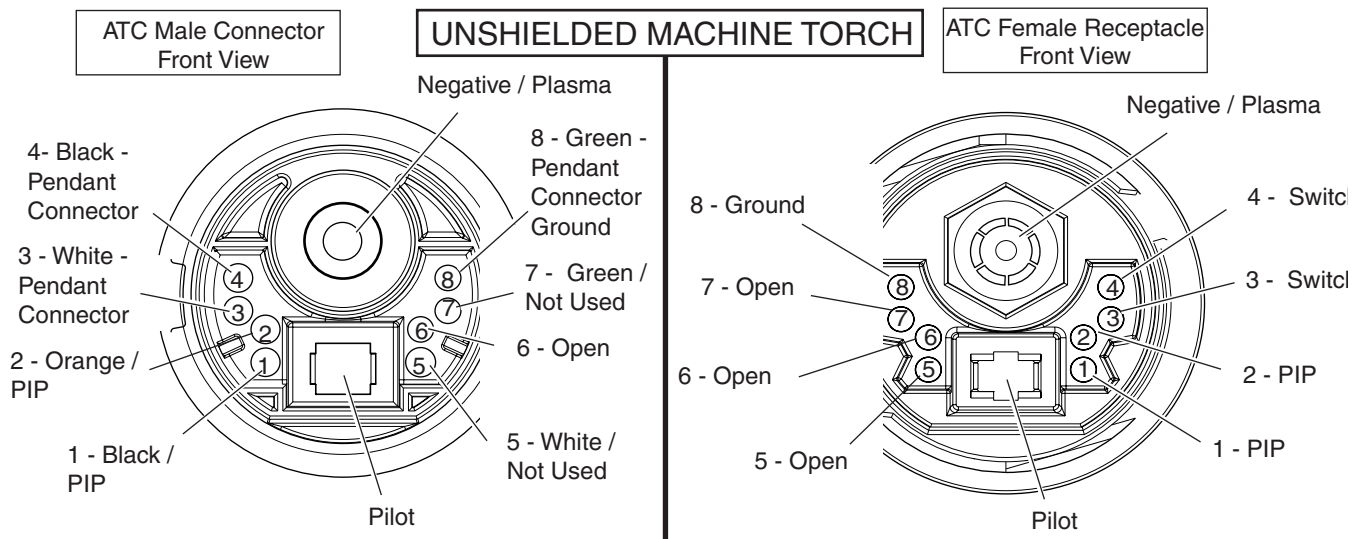

ESAB CUTMASTER 120

APPENDIX 4: TORCH CONNECTION DIAGRAMS

A. Hand Torch Connection Diagram

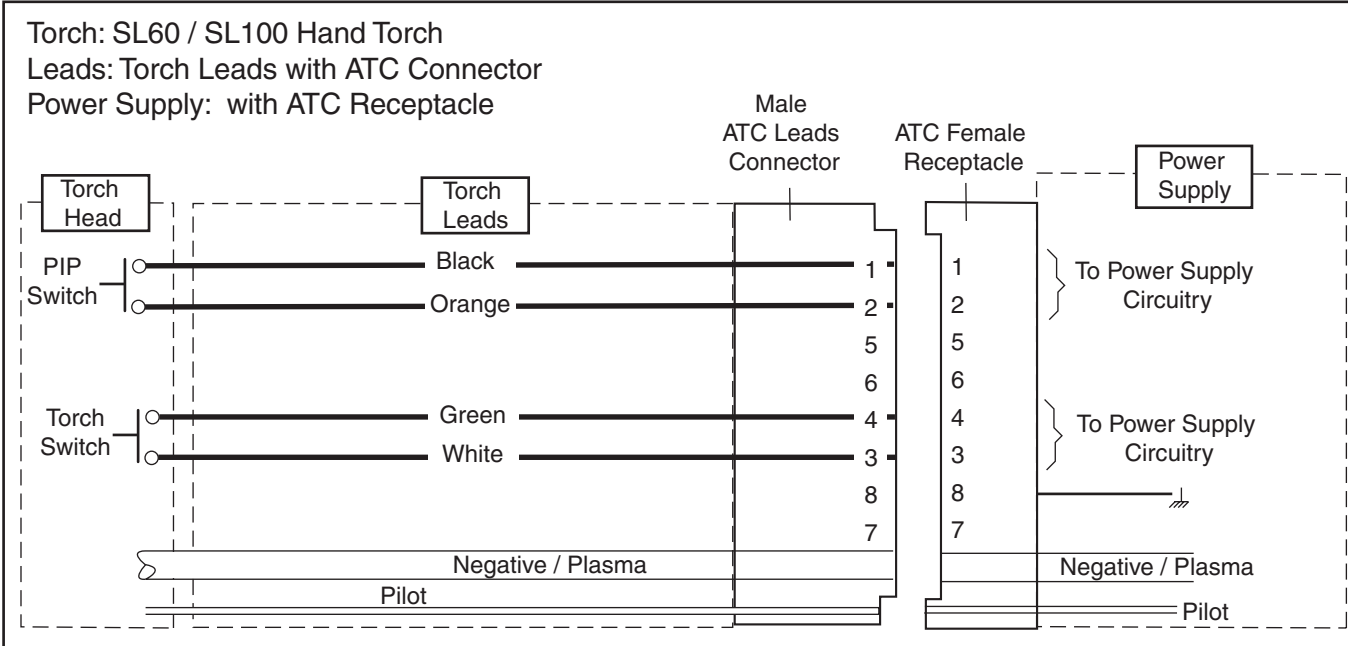

Art # A-03797

B. Mechanized Torch Connection Diagram

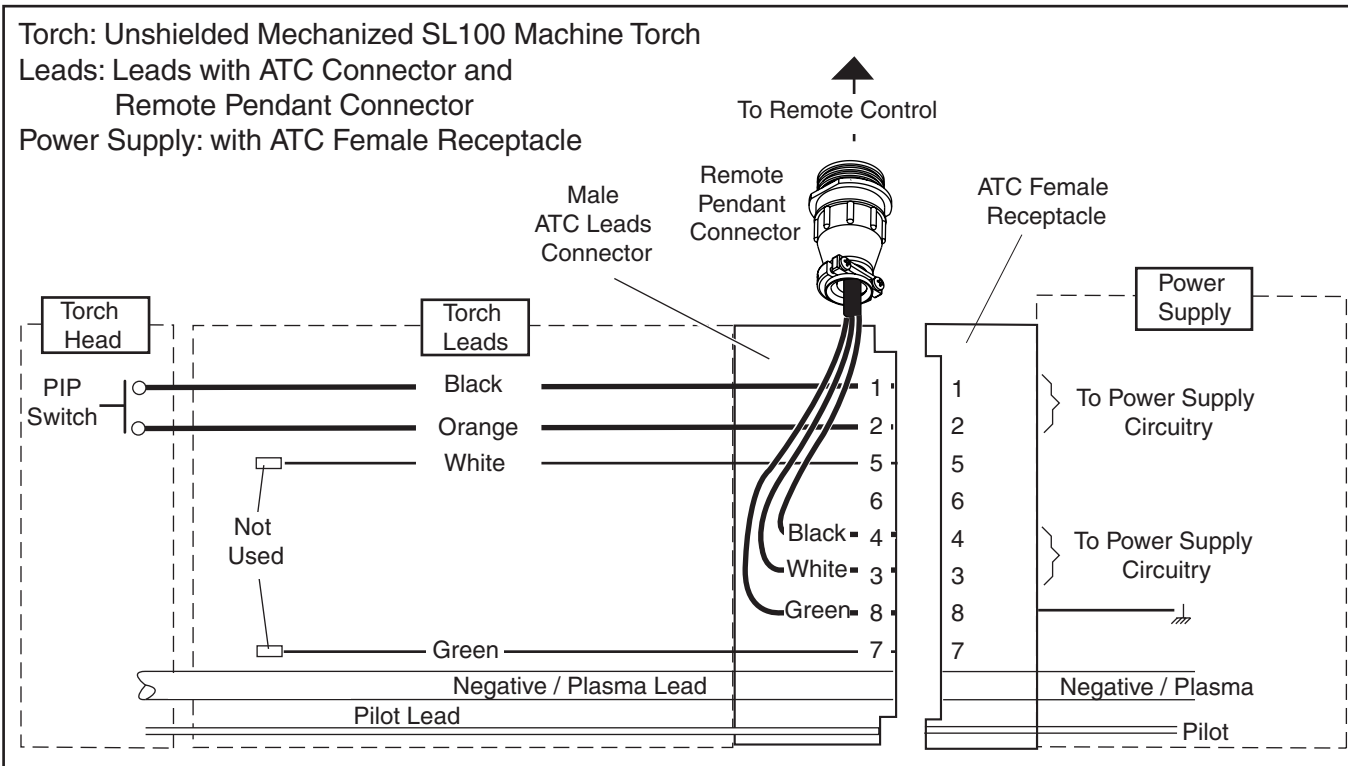

Art # A-03798

This Page Intentionally Blank

APPENDIX 5: SYSTEM SCHEMATIC, 400V UNITS

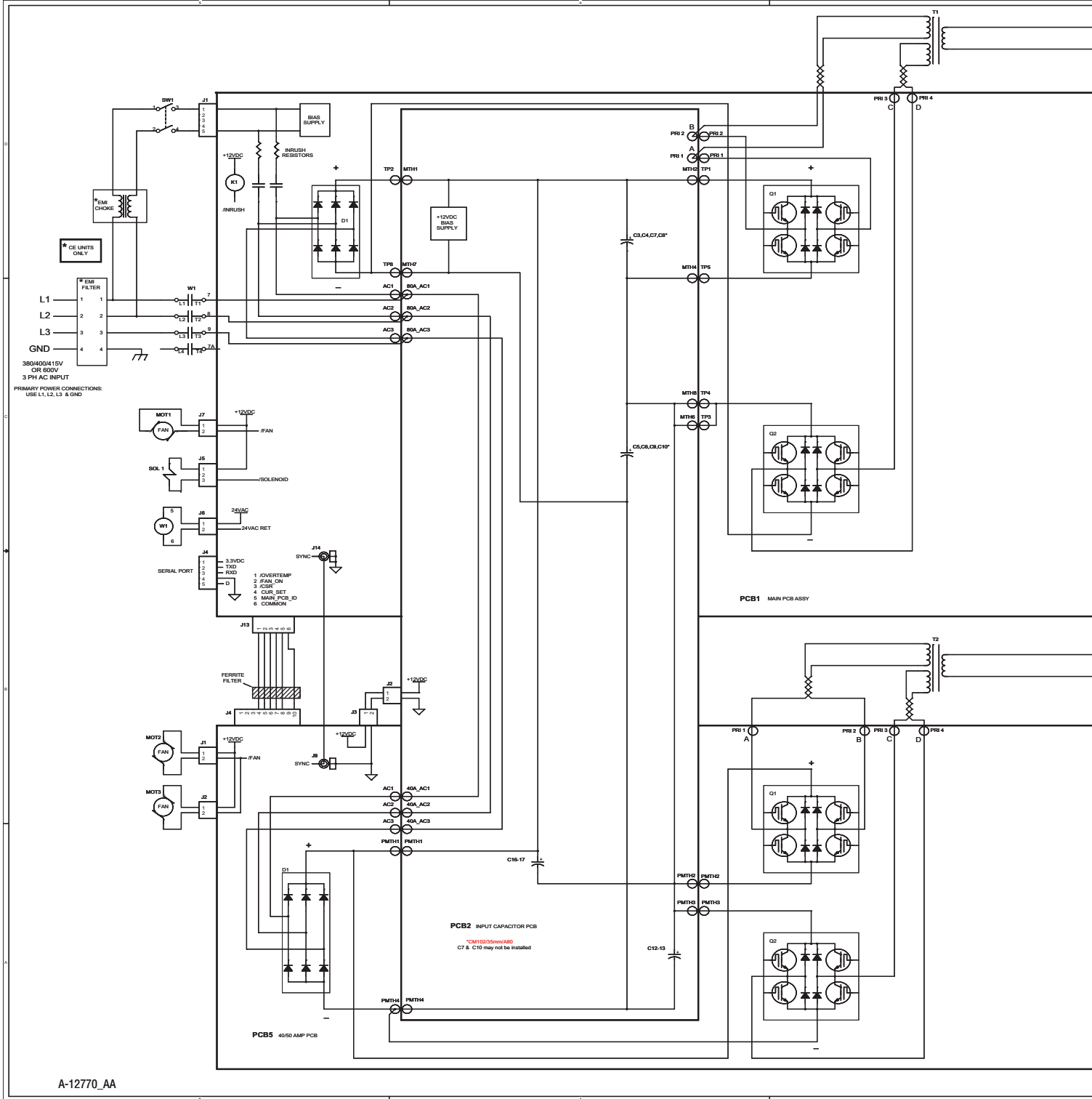

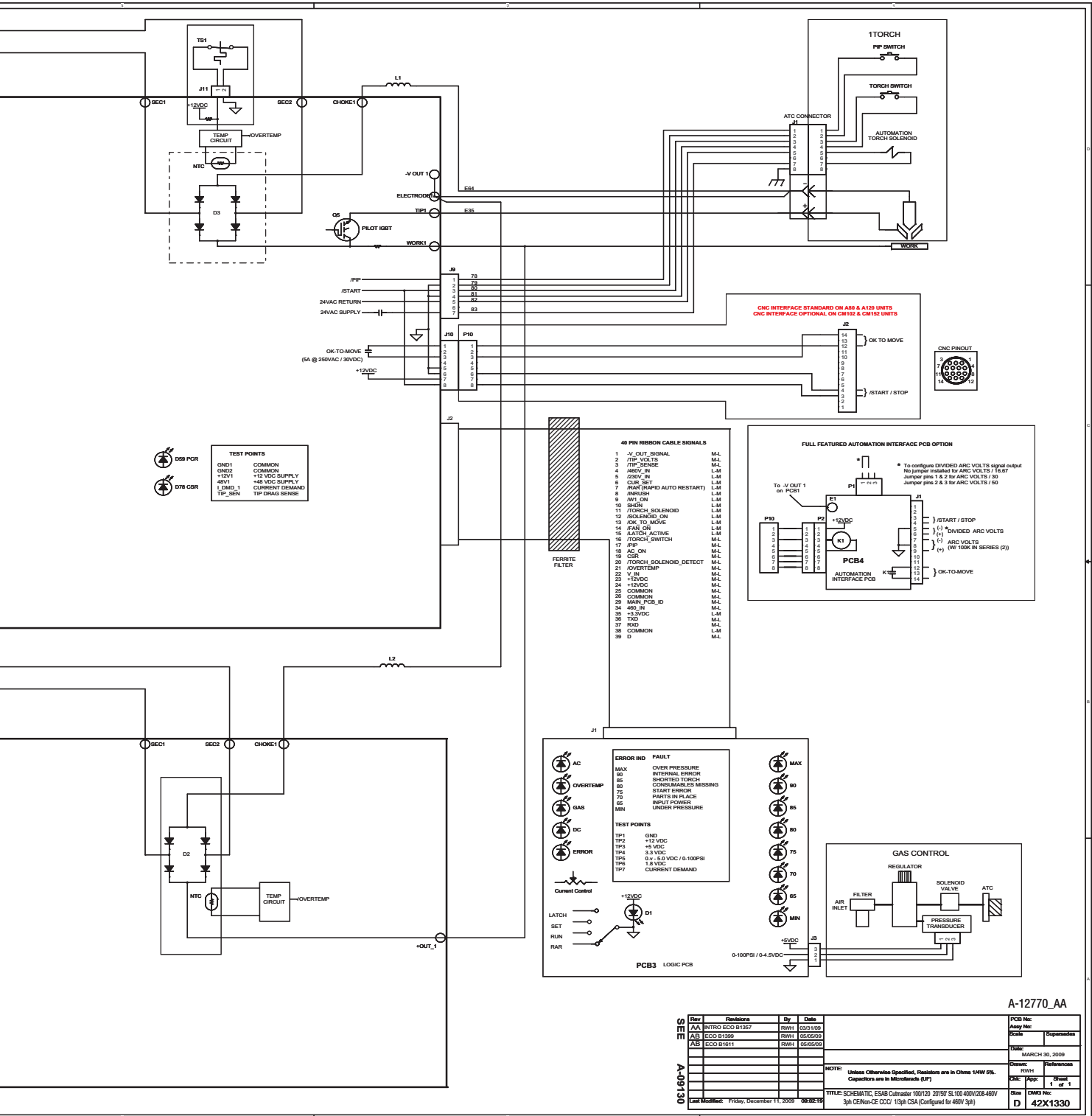

Revision History

Date	Rev	Description
01/15/2015	AA	Manual release
06/15/2015	AB	Corrected the rated duty cycle to show 120A @ 80%
08/14/2015	AC	Updated art on cover, Updated DoC, added duty cycle values, removed Shielded Machine Torch Leads Assemblies

This Page Intentionally Blank

ESAB subsidiaries and representative offices

Europe

AUSTRIA

ESAB Ges.m.b.H
Vienna-Liesing
Tel: +43 1 888 25 11
Fax: +43 1 888 25 11 85

BELGIUM

S.A. ESAB N.V.
Heist-op-den-Berg
Tel: +32 70 233 075
Fax: +32 15 257 944

BULGARIA

ESAB Kft Representative Office
Sofia
Tel/Fax: +359 2 974 42 88

THE CZECH REPUBLIC

ESAB VAMBERK s.r.o.
Vamberk
Tel: +420 2 819 40 885
Fax: +420 2 819 40 120

DENMARK

Aktieselskabet ESAB
Herlev
Tel: +45 36 30 01 11
Fax: +45 36 30 40 03

FINLAND

ESAB Oy
Helsinki
Tel: +358 9 547 761
Fax: +358 9 547 77 71

FRANCE

ESAB France S.A.
Cergy Pontoise
Tel: +33 1 30 75 55 00
Fax: +33 1 30 75 55 24

GERMANY

ESAB GmbH
Solingen
Tel: +49 212 298 0
Fax: +49 212 298 218

GREAT BRITAIN

ESAB Group (UK) Ltd
Waltham Cross
Tel: +44 1992 76 85 15
Fax: +44 1992 71 58 03
ESAB Automation Ltd
Andover
Tel: +44 1264 33 22 33
Fax: +44 1264 33 20 74

HUNGARY

ESAB Kft
Budapest
Tel: +36 1 20 44 182
Fax: +36 1 20 44 186

ITALY

ESAB Saldatura S.p.A.
Bareggio (Mi)
Tel: +39 02 97 96 8.1
Fax: +39 02 97 96 87 01

THE NETHERLANDS

ESAB Nederland B.V.
Amersfoort
Tel: +31 33 422 35 55
Fax: +31 33 422 35 44

NORWAY

AS ESAB
Larvik
Tel: +47 33 12 10 00
Fax: +47 33 11 52 03

POLAND

ESAB Sp.zo.o.
Katowice
Tel: +48 32 351 11 00
Fax: +48 32 351 11 20

PORTUGAL

ESAB Lda
Lisbon
Tel: +351 8 310 960
Fax: +351 1 859 1277

ROMANIA

ESAB Romania Trading SRL
Bucharest
Tel: +40 316 900 600
Fax: +40 316 900 601

RUSSIA

LLC ESAB
Moscow
Tel: +7 (495) 663 20 08
Fax: +7 (495) 663 20 09

SLOVAKIA

ESAB Slovakia s.r.o.
Bratislava
Tel: +421 7 44 88 24 26
Fax: +421 7 44 88 87 41

SPAIN

ESAB Ibérica S.A.
Alcalá de Henares (MADRID)
Tel: +34 91 878 3600
Fax: +34 91 802 3461

SWEDEN

ESAB Sverige AB
Gothenburg
Tel: +46 31 50 95 00
Fax: +46 31 50 92 22
ESAB international AB
Gothenburg
Tel: +46 31 50 90 00
Fax: +46 31 50 93 60

SWITZERLAND

ESAB AG
Dietikon
Tel: +41 1 741 25 25
Fax: +41 1 740 30 55

UKRAINE

ESAB Ukraine LLC
Kiev
Tel: +38 (044) 501 23 24
Fax: +38 (044) 575 21 88

North and South America

ARGENTINA

CONARCO
Buenos Aires
Tel: +54 11 4 753 4039
Fax: +54 11 4 753 6313

BRAZIL

ESAB S.A.
Contagem-MG
Tel: +55 31 2191 4333
Fax: +55 31 2191 4440

CANADA

ESAB Group Canada Inc.
Mississauga, Ontario
Tel: +1 905 670 02 20
Fax: +1 905 670 48 79

MEXICO

ESAB Mexico S.A.
Monterrey
Tel: +52 8 350 5959
Fax: +52 8 350 7554

USA

ESAB Welding & Cutting Products
Florence, SC
Tel: +1 843 669 44 11
Fax: +1 843 664 57 48

Asia/Pacific

AUSTRALIA

ESAB South Pacific
Archerfield BC QLD 4108
Tel: +61 1300 372 228
Fax: +61 7 3711 2328

CHINA

Shanghai ESAB A/P
Shanghai
Tel: +86 21 2326 3000
Fax: +86 21 6566 6622

INDIA

ESAB India Ltd
Calcutta
Tel: +91 33 478 45 17
Fax: +91 33 468 18 80

INDONESIA

P.T. ESABindo Pratama
Jakarta
Tel: +62 21 460 0188
Fax: +62 21 461 2929

JAPAN

ESAB Japan
Tokyo
Tel: +81 45 670 7073
Fax: +81 45 670 7001

MALAYSIA

ESAB (Malaysia) Snd Bhd
USJ
Tel: +603 8023 7835
Fax: +603 8023 0225

SINGAPORE

ESAB Asia/Pacific Pte Ltd
Singapore
Tel: +65 6861 43 22

Fax: +65 6861 31 95

SOUTH KOREA

ESAB SeAH Corporation
Kyungnam
Tel: +82 55 269 8170
Fax: +82 55 289 8864

UNITED ARAB EMIRATES

ESAB Middle East FZE
Dubai
Tel: +971 4 887 21 11
Fax: +971 4 887 22 63

Africa

EGYPT

ESAB Egypt
Dokki-Cairo
Tel: +20 2 390 96 69
Fax: +20 2 393 32 13

SOUTH AFRICA

ESAB Africa Welding & Cutting Ltd
Durbanvill 7570 - Cape Town
Tel: +27 (0)21 975 8924

Distributors

For addresses and phone numbers to our distributors in other countries, please visit our home page
www.esab.eu



www.esab.eu

