

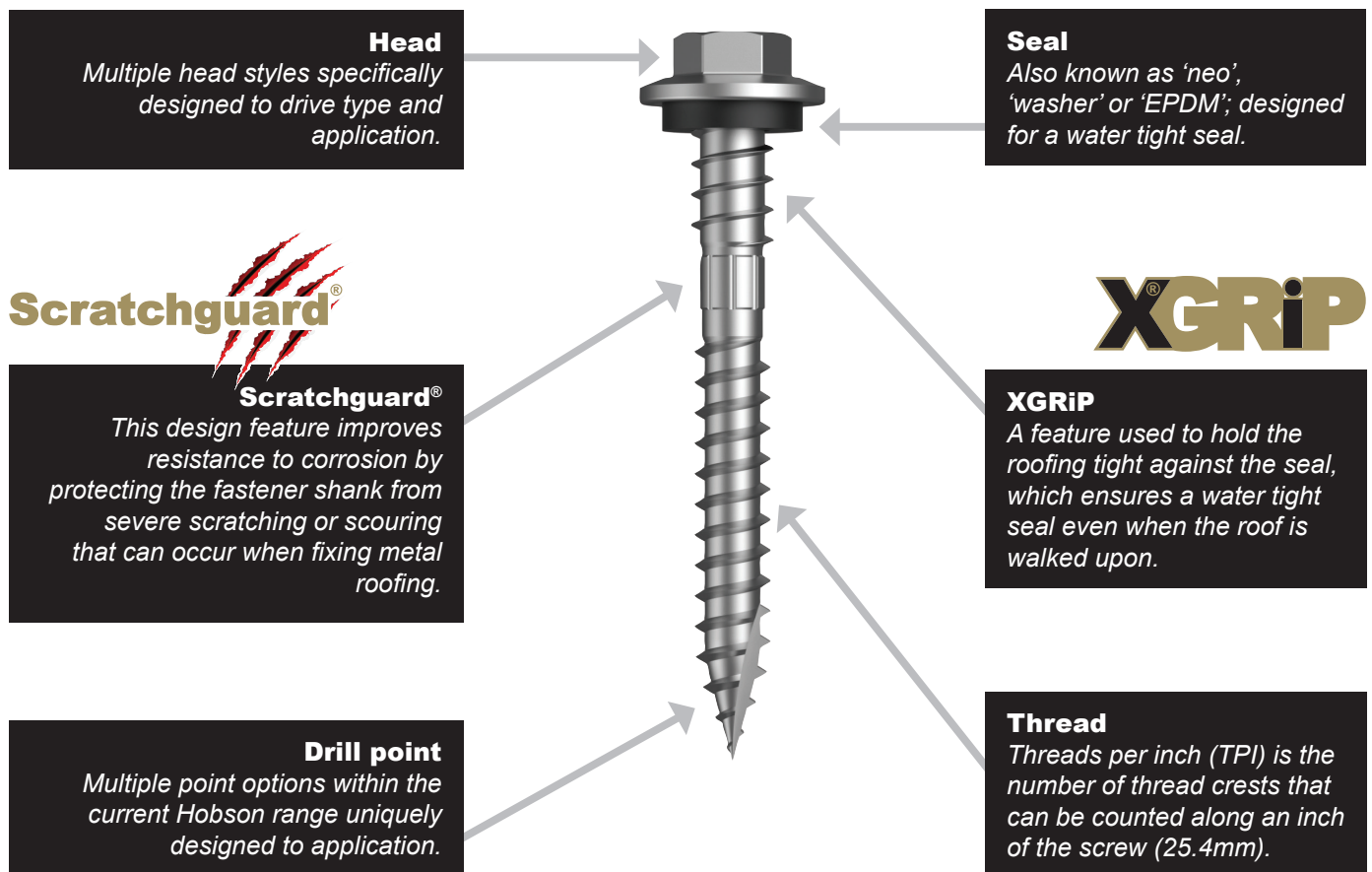

Self Drilling Screw Features

Manufactured for specific applications, these screws eliminate the need for pre-drilled holes and are engineered for ease of use. Basic features of the screw include:





Screw Size and Type Identification

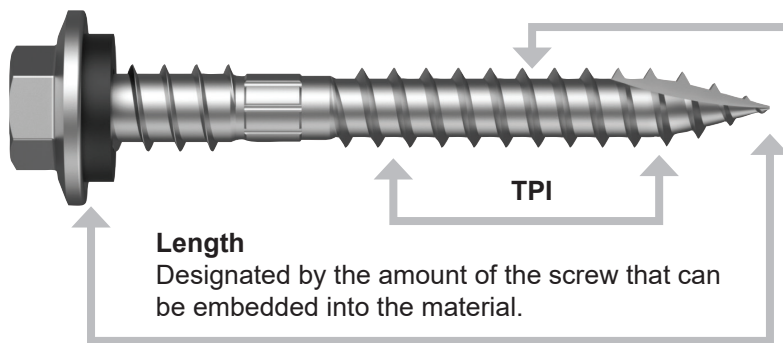

Screw Gauge

Thickness of thread major diameter.

Gauge	Major Diameter
6g	3.5mm
8g	4.2mm
10g	4.8mm
12g	5.5mm
14g	6.3mm

Identifying Head Stamping







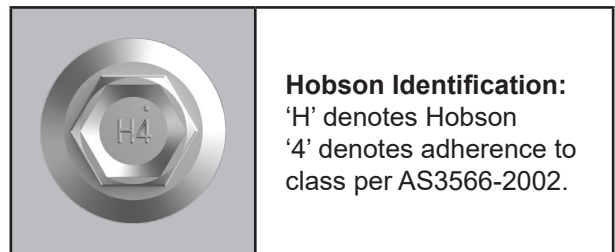





As per the AS 3566.1—2002 1.12 MARKING, the requirement for head stamping follows:

The manufacturer's identification mark and/or trademark shall be marked on the heads of the following screws:

- (a) Hexagon headed screws ST 4.8 (No. 10) and larger.
- (b) Bugle head screws Type 17 ST 4.8 (No. 10) and larger.
- (c) Class 3 or Class 4 corrosion resistant screws ST 4.8 (No. 10) and larger.



Drive Types

	Slotted		Hex Internal		Square		Eye
	Phillips		Hex External		Torx		Pozi
	Combi Slot Phillips		Post Hex		Post Torx		Trilobular



Measuring the Length of Screws

Screw types to measure from the underside of the head

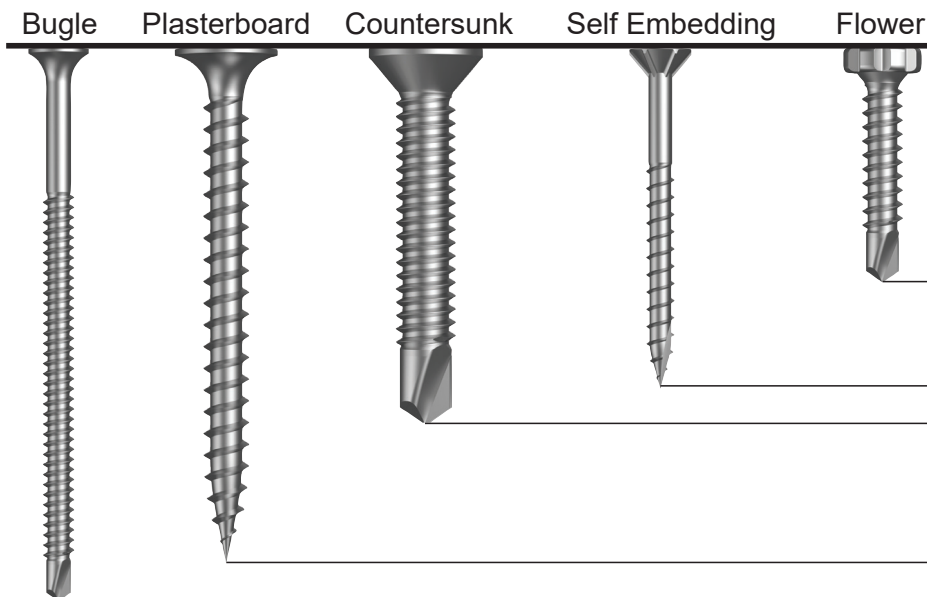
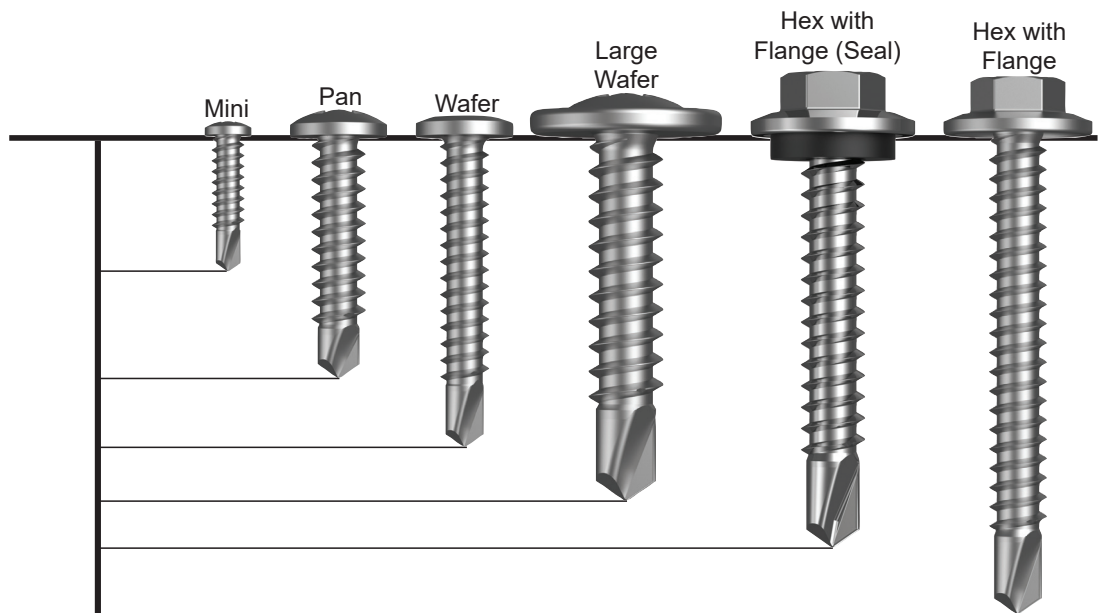

Screw types to measure from the top of the head



Screw Embedment

Maximises the ability of the screw to achieve the required pull out loads.

Timber

As a general rule, the minimum embedment required to achieve maximum pull out values is 25mm for #12 and 35mm for #14.

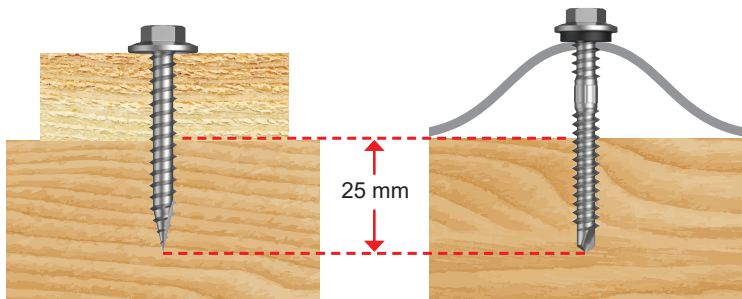

Metal

A minimum of three threads protruding to achieve maximum pull out values.

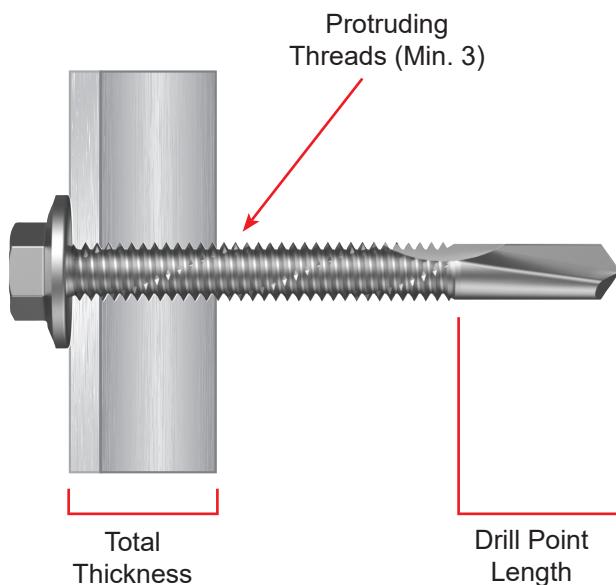

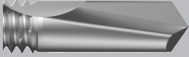
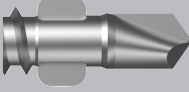
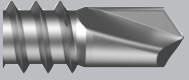
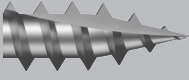
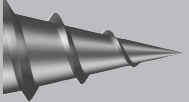
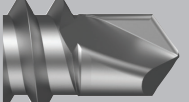
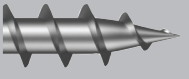

Screw Identification by Point Type

	<p>Series 500 (S) Commonly referred to as a deep driller, this point is designed for drilling and fastening into thick steel.</p>
	<p>Winged (G) This point is designed for fastening timber and/or composite materials to steel. The wings drill a hole through the timber or composite which is wider than the threads, preventing the threads from lifting the material and allowing the screw to self drill into the steel. The wings break off once the steel is engaged.</p>
	<p>Metal Point (M) This point is designed for drilling steel sections such as purlins, tophats, roofing and cladding. The length of the point will vary depending on steel thickness designed to drill.</p>
	<p>Type 17 (W) This point is designed for drilling through lighter steel sections and fastening with timber.</p>
	<p>Needle Point (N) This point is used on screws of a general purpose nature.</p>
	<p>vmaX® (V) Universal drilling point, suitable for fastening steel to timber. Ideal for roofing applications.</p>
	<p>Chipboard / Treated Pine (D) This point is designed for fastening chipboard or timber.</p>







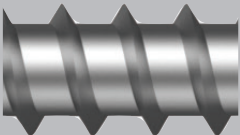
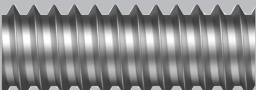











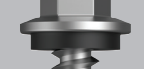
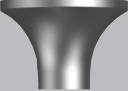

Determining Thread Type

Thread per inch (TPI) is the number of thread crests that can be counted along an inch (25.4mm).

	<p>Coarse thread (up to 16TPI)</p> <p>Otherwise known as space threads, screws with a <i>coarse thread</i> are generally used for timber applications and for lighter steel sections.</p> <ul style="list-style-type: none"> → Simple rule of thumb – coarse thread secures lighter steel sections. → Typical applications in pre-engineered steel buildings include: cladding, framing and roofing. → Common sizes include 10g-16TPI; 12g-14TPI and 14g-10TPI.
	<p>Fine thread (over 16TPI)</p> <p>Generally known as <i>metal threads</i>, these screws are only used in steel applications and particularly thicker steels from 2mm upward.</p> <ul style="list-style-type: none"> → Simple rule of thumb – fine thread secures heavier steel sections. → Typical applications in pre-engineered steel buildings include: framing (brackets to purlins) and roofing (lapped purlins). → Common sizes include 8g-18TPI; 10g-24TPI and 12g-24TPI.

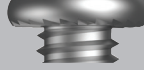
Screw Head and Seal Styles

	Hex Flange Head		Pan Head		Washer Head
	Countersunk		Mini Pan		Large Washer Head
	Countersunk Ribbed		Large Wafer		Flower
	Undercut Countersunk		Wafer		Hex Head with Seal
	Bugle		Button Head		Hex Head with EPDM Seal
	Bugle Batten Ribbed		Flat Head		Hex Head with Multiseal
	Trim Head Ribbed		Flat Serrated		Hex Head with Aluminium Seal